

FEATURES:

- Built-in ISO 5211 Direct Mounting Pad and Square Stem for Easy Automation
- Anti-Static Devices for Ball-Stem-Body
- Blow-out Proof Stem
- Pressure Balance Hole in Ball Slot
- Pre-Load 2 Belleville Washers to Self-adjust Packing
- **TA-LUFT** Design Approved

STANDARDS:

- Design: ASME B16.34, API 608
- Wall Thickness: EN 12516-3
- Pipe Thread **KV-L30**: ASME B1.20.1, BS21
DIN 2999 / 259, ISO 228 / 1
JIS B 0203, ISO 7 / 1
- Butt Weld **KV-L31**: ASME B16.25 (φB2 Sch 40)
φB2 Available in Sch 10, 20
- Socket Weld **KV-L32**: ASME B16.11
- Flanged End **KV-L3F**: ASME B16.5 CLASS 150/300
EN 1092-1 PN10-40
JIS B2238 10K / 20K
- Inspection & Testing: API 598, EN 12266

NO	PART NAME	MATERIALS		
1	Body	CF8M	CF8	WCB
2	Cap (Thread)	CF8M	CF8	WCB
	Cap (Welding)	CF3M		
3	Ball	CF8M	CF8	
4	Ball Seat	TFM 1600 / PTFE / RTFE		
5	Stem	SUS 316	SUS 304	
6	Anti-Static Device	SUS 316	SUS 304	
7	Thrust Washer	PTFE		
8	O-Ring	FKM (VITON)		
9	Stem Packing	PTFE		
10	Bushing	50%SS+50%PTFE		
11	Gland	SUS 316		
12	Belleville Washer	SUS 301		
13	Stem Nut	A194-8		
14	Stop-Lock-Cap	SUS 304		
15	Bolting	A193-B8		
16	Bolt Washer	SUS 304		
17	Bolt Nut	A194-8		
18	Body Gasket	PTFE		
19	Hex Bolting	A193-B8		
20	Actuator	Pneumatic KP / Electric KQ		

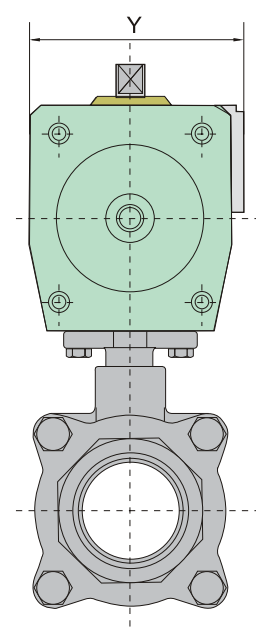
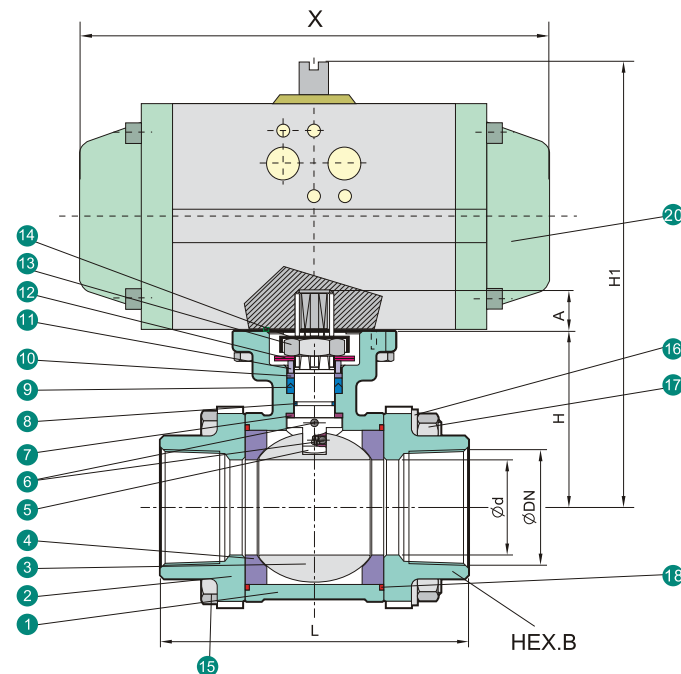
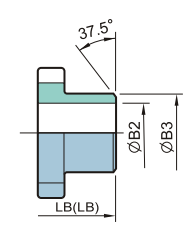
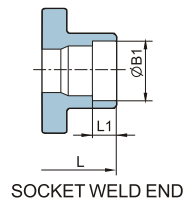
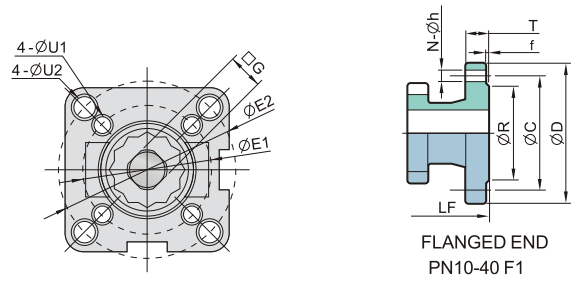

SIZE	φd	L	LB	LE	LF	H	H1	φE1	φE2	G	φU1	φU2	A	φD	φC	φR	T	f	N	φh	L1	φB1	φB2	φB3	X	Y	P-Actuator	E-Actuator	Pressure
1/4"	10.6	75	70	225	—	42.0	—	36.	42.	9	6	6.0	9	—	—	—	—	—	—	—	10.0	14.2	10.6	18	144	72	KP50	KQ006	80PSI
3/8	12.7	75	70	225	—	42.0	—	36	42	9	6	6.0	9	—	—	—	—	—	—	—	10.0	17.8	12.7	18	144	72	KP50	KQ006	80PSI
1/2"	15.0	75	75	225	130	42.0	169	36	42	9	6	6.0	9	95	65.0	45.0	16	2.0	4	14	10.0	21.8	15.8	22	144	72	KP50	KQ006	80PSI
3/4"	20.0	80	90	225	150	48.5	177	36	50	9	6	7.0	9	105	75.0	58.0	18	2.0	4	14	13.0	27.3	20.9	28	144	72	KP50	KQ006	80PSI
1"	25.0	90	100	245	160	58.5	200	42	50	11	6	7.0	11	115	85.0	68.0	18	2.0	4	14	13.0	34.0	26.7	34	164	84	KP63	KQ006	80PSI
1-1/4"	32.0	110	110	255	180	63.0	215	42	70	11	6	9.0	11	140	100.0	78.0	18	2.0	4	18	16.0	42.8	35.1	43	164	84	KP63	KQ006	80PSI
1-1/2"	38.0	120	125	260	200	71.0	234	50	70	14	7	9.0	14	150	110.0	88.0	18	3.0	4	18	16.0	48.9	40.9	50	208	96	KP75	KQ008	80PSI
2"	50.0	140	150	275	230	78.0	241	50	70	14	7	9.0	14	165	125.0	102.0	20	3.0	4	18	17.0	61.4	52.5	61	208	96	KP75	KQ008	80PSI
2-1/2"	63.5	185	190	334	290	100.0	291	70	102	17	9	11.0	17	185	145.0	122.0	22	3.0	8	18	17.0	74.0	62.7	76	248	108	KP88	KQ015	80PSI
3"	76.0	205	220	354	310	109.0	313	70	102	17	9	11.0	17	200	160.0	138.0	24	3.0	8	18	17.0	90.0	78.0	92	268	123	KP100	KQ015	80PSI
4"	100.0	240	270	365	350	140.0	400	—	102	22	—	11.0	22	235	190.0	162.0	24	3.0	8	22	20.0	115.4	102.4	115	345	151	KP100	KQ020	80PSI

Unit:mm