

BALL VALVES
DISTRICT ENERGY
+ STEAM

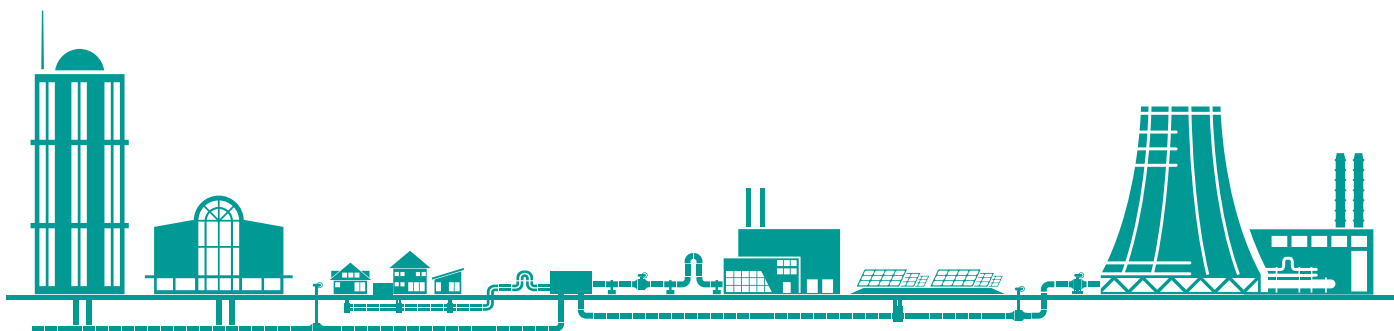

PERFORMANCE FROM START TO FINISH



When nothing but the best is good enough, BÖHMER district heating ball valves perform to meet the most demanding requirements.

Especially for underground operation a service life of at least 30 years is absolutely necessary for operational safety. Thanks to the design of our ball seat system, district heating ball valves from our factories are the perfect solution, not least because they require no maintenance.

These district heating ball valves can be used for numerous applications. Regardless of whether for underground district heating systems, transfer stations or in-building piping – BÖHMER district heating ball valves ensure such a high level of operational safety that they are almost indispensable.

Decades of experience mean that BÖHMER GmbH stands for top product quality. Our ball valves are certified according to current standards and regulations and they ensure extremely low losses of pressure.



Ball Valve for underground installation DN 1000



Tapping Ball Valve DN 300

CONTENT

10 Arguments in favor of Böhmer Ball Valves	04 - 05
--	----------------

Ball Valves for Underground Installation

BBFKSF - V - HE	Ball Valve with Weld ends for underground installation, Full Bore.....	08 - 10
BBFKSF - V - HE	Ball Valve with Weld ends for underground installation, Reduced Bore ...	11 - 13
BBFEMG/ESF - V - HE	Ball Valve for Venting and Draining with flange and Weld end.....	14
BBFELF/EMG - V - HE	Ball Valve for Venting and Draining with thread and Weld end	15
BBFKSF - V - HE	Tie-in Ball Valve /Ball Valve for one time operation, Full Bore	16
BBFKSF - R - HE	Tie-in Ball Valve /Ball Valve for one time operation, Reduced Bore.....	17
BBFKSF - V - HE	Tapping ball valve	18

Ball Valves for In Building Installation

BBFKSF - V - HS	Ball Valve with Weld Ends, Full Bore.....	20 - 21
BBFKSF - R - HS	Ball Valve with Weld Ends, Reduced Bore	22 - 23
BBFFSK - V - HS	Ball Valve with Flanges, Short Pattern, Full Bore	24 - 25
BBFFSK - R - HS	Ball Valve with Flanges, Short Pattern, Reduced Bore	26 - 27
BBFFSL - V - HS	Ball Valve with Flanges, Long Pattern, Full Bore	28
BBFFSK/KSF - V - HS	Ball Valve with Flange and Weld End, Full Bore	29
BBFKSG/KSF - V - HS	Ball Valve with Thread and Weld End, Full Bore.....	30
BBFKSG - V - HS	Ball Vale with Threaded Ends, Full Bore	31
BBFKSF - V - HS	Tapping Valve for Indoor Installation, Full Bore.....	32

Options und Accessories

Operating Accessories for Underground Ball Valves	34
Counter Flaps	35
Stem Extension	36
Options Overview	37
Actuators for District Heating Ball Valves	38
Drilling System for District Heating Ball Valves.....	39
Further Designs of Ball Valves.....	40

Technical Details

Wall thicknesses	42
Flange dimensions	42
Permissible tensile and compressive forces.....	43
Drag coefficients	43

TEN ADVANTAGES IN FAVOR OF BÖHMER BALL VALVES

We know that our products deliver what they promise. To give you an idea of the numerous advantages of our ball valves, we have compiled the following list of some of the special features.

01

The **solid body components** ensure the highest level of operational safety even under extreme conditions.

02

The **full penetration of the weld seams** enables our ball valves to withstand even extreme stresses, thus ensuring safe operation of the valves.

03

The **spring-supported Seat Rings** ensure longer service life and constitute the basis for fulfilling double block and bleed requirements.

04

The **extended weld ends** fulfill more than the required standard, while machining operations ensure absolute roundness of the weld ends.

05

The **trunnion-mounted ball** increases the service life of the valve by reducing stresses.

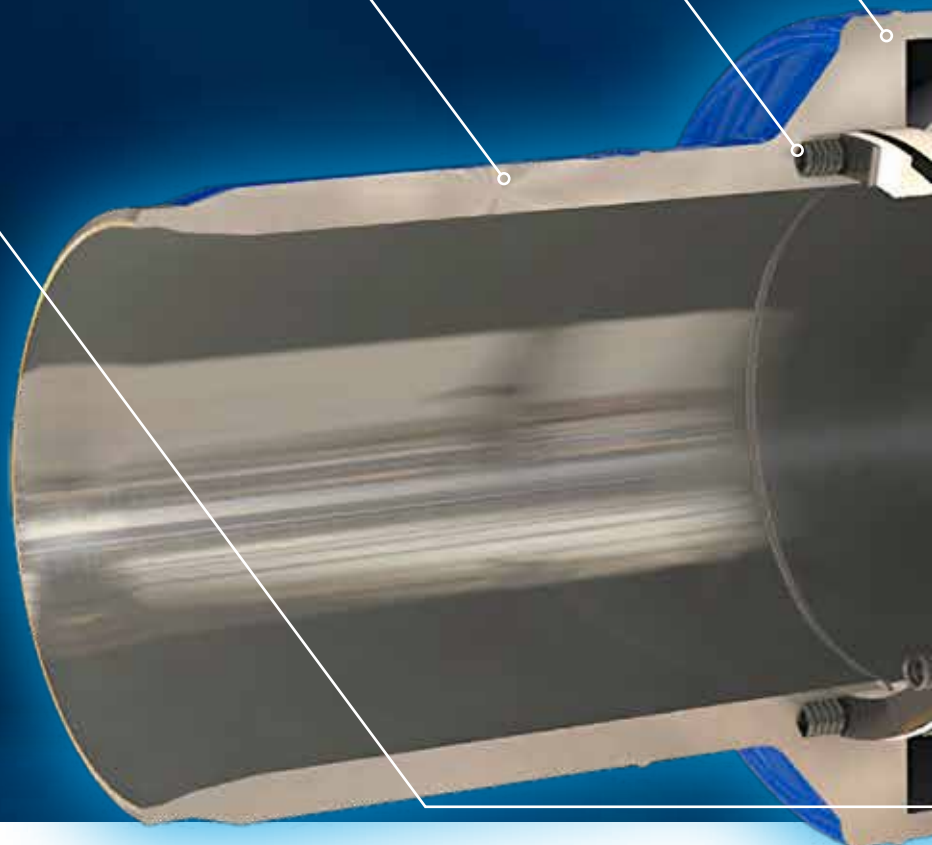

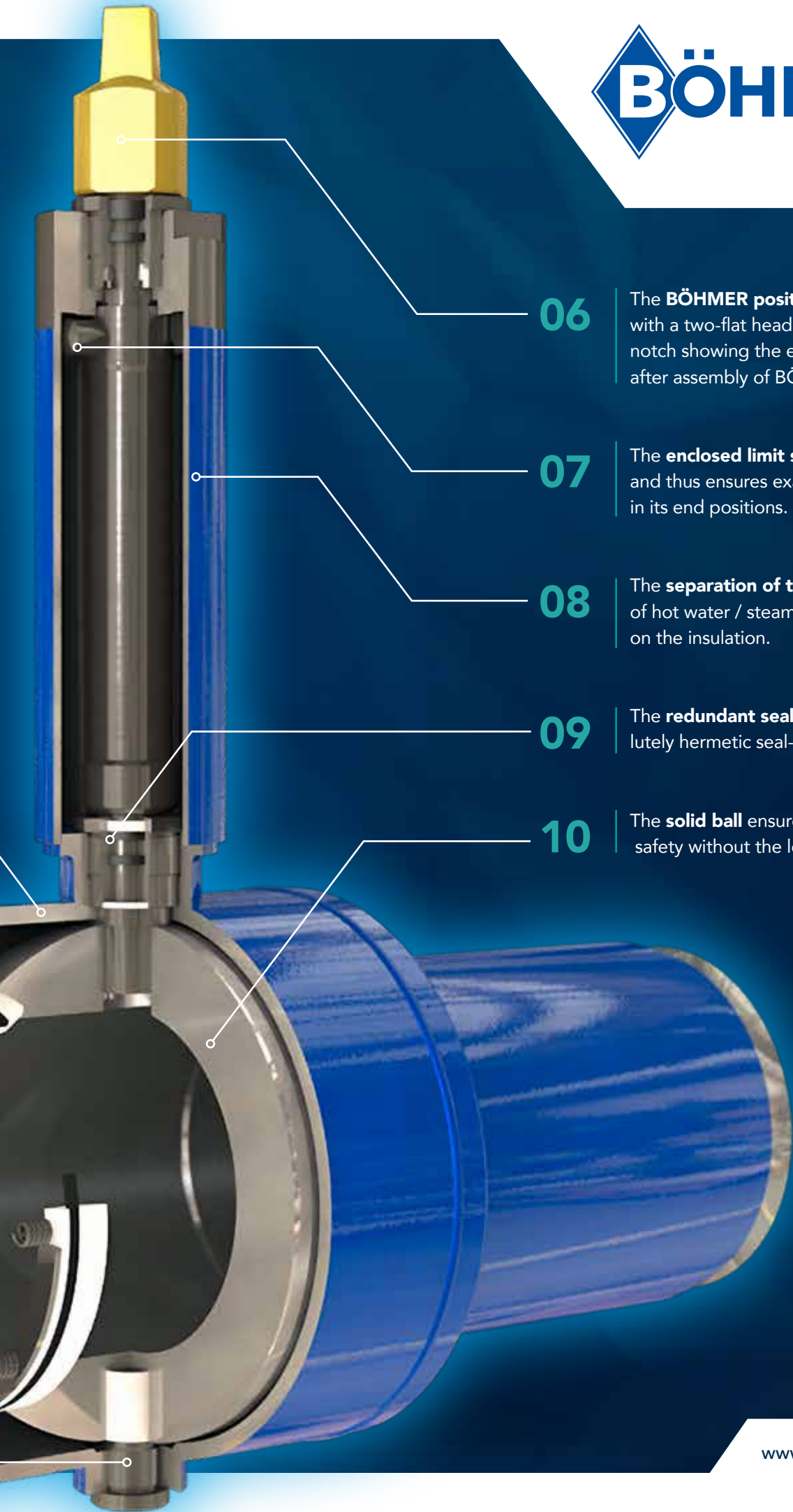

06

The **BÖHMER position indicator** is designed with a two-flat header and a red-colored direction notch showing the exact position of the ball even after assembly of BÖHMER accessories.

07

The **enclosed limit stop** is not exposed to dirt and thus ensures exact positioning of the valve in its end positions.

08

The **separation of the extension** from the flow of hot water / steam reduces the thermal stress on the insulation.

09

The **redundant seal of the stem** ensures absolutely hermetic seal-off from the environment.

10

The **solid ball** ensures top operational safety without the loss of flow.

THE BÖHMER- DISTRICT ENERGY PROGRAM

Thanks to our comprehensive product portfolio, we are able to fulfill almost all customer demands and requests. In contrast to other manufacturers, we manufacture all our district heating ball valves according to a modular system which has proved its worth for decades, regardless of whether the ball valve is destined for pre-insulated underground installation or for above-ground installation.

Our district heating ball valves are certified according to international standards currently in force throughout the world and they excel in their minimum loss of pressure and high operational safety.



Standard valves for building installation up to DN 400 in stock



Standard valves for buried installation up to DN 500 in stock

Specifications of our district energy ball valves

Nominal sizes:	DN 15 up to DN 1200 (on request up to DN 1400)
Pressure levels:	up to PN 40
Temperatures:	up to +250 °C (on request)
Body materials:	Forged steel, Stainless steel (V4A only)
Ball materials:	Forged steel, Stainless steel
Stem materials:	Stainless steel
Seal materials:	EPDM, PTFE and special materials
Actuators:	Levers, gearboxes, pneumatic, electric and hydraulic actuators



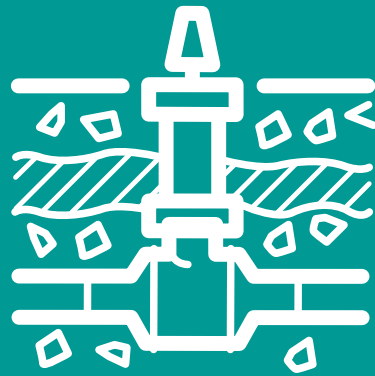

BALL VALVES FOR UNDERGROUND INSTALLATION



BBF/KSF-V-HE

BALL VALVE WITH WELD ENDS FOR UNDERGROUND INSTALLATION

DN 25-125 | PN 25

FULL BORE



INFORMATION

Ball Valve with Weld ends

/// Buried ball valves comply with the EN 488 standard

/// Suitable for the cold laying method

/// Operating temperature up to +150 °C

/// The square key is included in the delivery.

/// Underground ball valves are supplied unpainted as standard.

From DN 125:

/// The trunnion mounted ball is standard

MATERIALS

Body	Forged Steel / Steel
Weld Ends	Steel
Ball	Stainless Steel
Seat Rings	PTFE
Stem Seals	EPDM

OPTIONS

/// Suitable for steam

/// Additional extensions for adjusting the overlap height and other accessories can be found from page 34 onwards

/// For deviating operating conditions please send us a written request stating the fluids, as well as the pressure and temperature range.

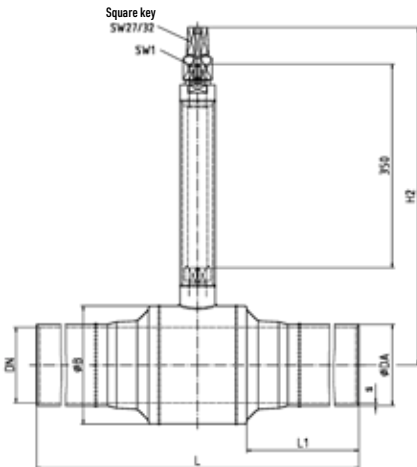

DN [mm]	PN [bar]	DA [mm]	s* [mm]	L [mm]	L1 [mm]	B [mm]	H2 [mm]	SW1 [mm]	Weight [kg]	Art-No.
25	25	33.7	2.3	1500	717	54	465	16	8.0	076.0142
32	25	42.4	2.6	1500	708.5	64	488	16	9.3	076.0107
40	25	48.3	2.6	1500	706	76	493	16	11.0	076.0109
50	25	60.3	2.9	1500	705.5	89	501	16	14.0	076.0044
65	25	76.1	2.9	1500	691	121	515	16	19.0	076.0046
80	25	88.9	3.2	1500	688	140	549	22	25.0	076.0048
100	25	114.3	3.6	1500	680	171	562	22	34.0	076.0079
125	25	139.7	3.6	1500	665	203	581	22	45.0	076.0096

* The alignment of the wall thickness of the pipe end is carried out according to measurement „s“. The actual wall thicknesses used can be found in the table on page 42 of this catalogue.



BBF/KSF-V-HE

BALL VALVE WITH WELD ENDS FOR UNDERGROUND INSTALLATION



DN 150-300 | PN 25

FULL BORE

INFORMATION

Ball Valve with Weld ends

/// Buried ball valves comply with the EN 488 standard

/// Suitable for the cold laying method

/// Operating temperature up to +150 °C

/// Underground ball valves are supplied unpainted as standard.

/// The trunnion mounted ball is standard

/// For the operation we recommend the use of a plug in gear box. The flange connection required for the use of the plug in gear box, as well as the square key is included in the delivery.

MATERIALS

Body	Forged Steel / Steel
Weld Ends	Steel
Ball	Stainless Steel
Seat Rings	PTFE
Stem Seals	EPDM

OPTIONS

/// Suitable for steam

/// Additional extensions for adjusting the overlap height and other accessories can be found from page 34 onwards

/// For deviating operating conditions please send us a written request stating the fluids, as well as the pressure and temperature range.

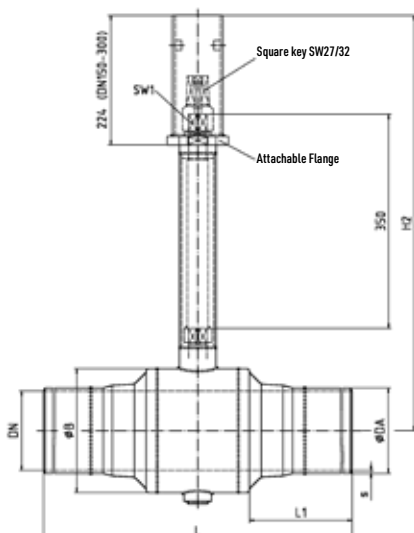

DN [mm]	PN [bar]	DA [mm]	s* [mm]	L [mm]	L1 [mm]	B [mm]	H2 [mm]	SW1 [mm]	Weight [kg]	Art.-No.
150	25	168.3	4.0	1500	640.5	254	725	32	85	076.0098
200	25	219.1	4.5	1500	616	324	760	32	129	076.0105
250	25	273.0	5.0	1500	567	407	900	32	285	076.0113
300	25	323.9	5.6	2000	771	508	942	32	510	076.0115

* The alignment of the wall thickness of the pipe end is carried out according to measurement „s“. The actual wall thicknesses used can be found in the table on page 42 of this catalogue.

BBF/KSF-V-HE

BALL VALVE WITH WELD ENDS FOR UNDERGROUND INSTALLATION



DN 350-1200 | PN 25

FULL BORE

INFORMATION

Ball Valve with Weld ends

/// Buried ball valves comply with the EN 488 standard

/// Suitable for the cold laying method

/// Operating temperature up to +150 °C

/// The trunnion mounted ball is standard

/// Underground ball valves are supplied unpainted as standard.

/// The angular gear and the square key are included in the delivery.

MATERIALS

Body	Forged Steel / Steel
Weld Ends	Steel
Ball	Steel chemically nickel plated
Seat Rings	PTFE
Stem Seals	EPDM

OPTIONS

/// Suitable for steam

/// Additional extensions to adjust the overlap height (for version 2 and 3) in the lengths 350, 500, 750 and 1000 mm are available on request at short notice.

/// For deviating operating conditions please send us a written request stating the fluids, as well as the pressure and temperature range.

Version 1

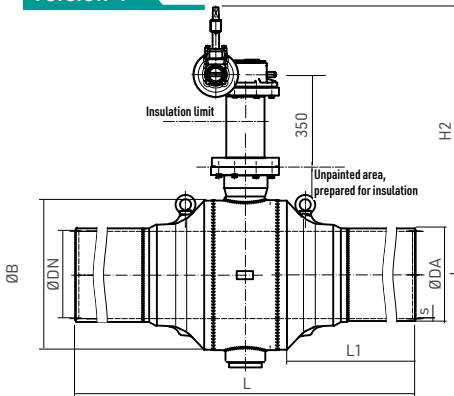

Version 2

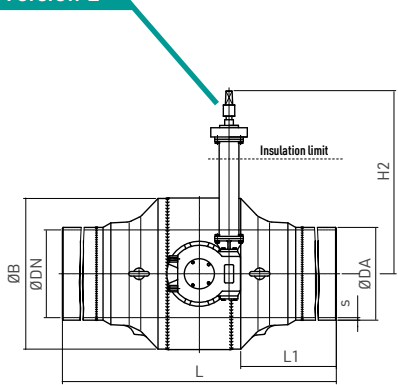

Version 3

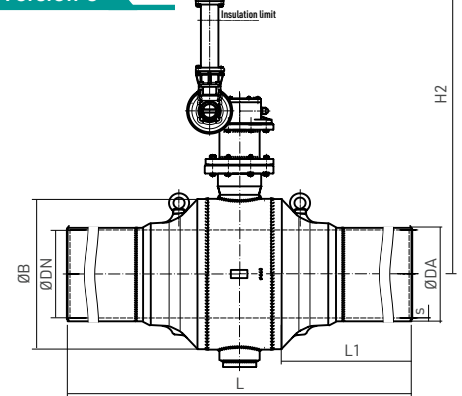

DN [mm]	PN [bar]	DA [mm]	s* [mm]	L [mm]	L1 [mm]	B [mm]	Weight [kg]
350	25	355.6	5.6	2000	745	559	750
400	25	406.4	6.3	2000	819	660	1030
450	25	457	6.3	2000	684	720	1700
500	25	508.0	6.3	2500	890	814	2200
600	25	610	7.1	3000	1087	955	ca. 3000
700	25	711	8.0	3000	1040	1116	ca. 4500
800	25	813	8.8	3000	1232	1261	ca. 5700
900	25	914	10	3000	a. A.	1396	ca. 7400
1000	25	1016	11	3000	1176	1561	ca. 11000
1200	25	1220	12.5	a. A.	a. A.	1890	ca. 19000

Version 1		Version 2		Version 3	
H2 [mm]	Art.-No.	H2 [mm]	Art.-No.	H2 [mm]	Art.-No.
1086	a. A.	800	a. A.	1274	a. A.
1121	a. A.	800	a. A.	1368	a. A.
1215	a. A.	800	a. A.	1404	a. A.
1256	a. A.	800	a. A.	1445	a. A.
a. A.	a. A.	a. A.	a. A.	a. A.	a. A.
a. A.	a. A.	a. A.	a. A.	a. A.	a. A.
a. A.	a. A.	a. A.	a. A.	a. A.	a. A.
a. A.	a. A.	a. A.	a. A.	a. A.	a. A.
a. A.	a. A.	a. A.	a. A.	a. A.	a. A.
a. A.	a. A.	a. A.	a. A.	a. A.	a. A.

* The alignment of the wall thickness of the pipe end is carried out according to measurement „s“. The actual wall thicknesses used can be found in the table on page 42 of this catalogue.

Ball Valves DN600 and above will be custom designed to meet order specifications. Please take note of the drawings submitted in case of an order.

BBF/KSF-R-HE

BALL VALVE WITH WELD ENDS FOR UNDERGROUND INSTALLATION



DN 40-150 | PN 25

REDUCED BORE

INFORMATION

Ball Valve with Weld ends

/// Buried ball valves comply with the EN 488 standard

/// Suitable for the cold laying method

/// Operating temperature up to +150 °C

/// The square key is included in the delivery.

/// Underground ball valves are supplied unpainted as standard.

From DN 150:

/// The trunnion mounted ball is standard

MATERIALS

Body	Forged Steel / Steel
Weld Ends	Steel
Ball	Stainless Steel
Seat Rings	PTFE
Stem Seals	EPDM

OPTIONS

/// Suitable for steam

/// Additional extensions for adjusting the overlap height and other accessories can be found from page 34 onwards

/// For deviating operating conditions please send us a written request stating the fluids, as well as the pressure and temperature range.

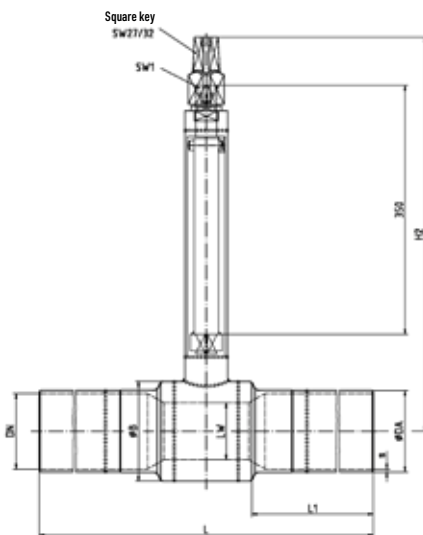

DN/LW [mm]	PN [bar]	DA [mm]	s* [mm]	L [mm]	L1 [mm]	B [mm]	H2 [mm]	SW 1 [mm]	Weight [kg]	Art.-No.
40/32	25	48.3	2.6	1500	712	64	488	16	11.0	076.0112
50/40	25	60.3	2.9	1500	710	76	493	16	12.5	076.0045
65/50	25	76.1	2.9	1500	705	89	501	16	17.0	076.0047
80/65	25	88.9	3.2	1500	694	121	515	16	22.0	076.0049
100/80	25	114.3	3.6	1500	688	140	549	22	30.0	076.0080
125/100	25	139.7	3.6	1500	680	171	562	22	39.5	076.0097
150/125	25	168.3	4.0	1500	667	203	581	22	51.3	076.0104

* The alignment of the wall thickness of the pipe end is carried out according to measurement „s“. The actual wall thicknesses used can be found in the table on page 42 of this catalogue.

BBF/KSF-R-HE

BALL VALVE WITH WELD ENDS FOR UNDERGROUND INSTALLATION

DN 200-400 | PN 25

REDUCED BORE



INFORMATION

Ball Valve with Weld ends

/// Buried ball valves comply with the EN 488 standard

/// Suitable for the cold laying method

/// Operating temperature up to +150 °C

/// The trunnion mounted ball is standard

/// Underground ball valves are supplied unpainted as standard.

/// For the operation we recommend the use of a plug in gear box. The flange connection required for the use of the plug in gear box, as well as the square key is included in the delivery.

MATERIALS

Body	Forged Steel / Steel
Weld Ends	Steel
Ball	Stainless Steel
Seat Rings	PTFE
Stem Seals	EPDM

OPTIONS

/// Suitable for steam

/// Additional extensions for adjusting the overlap height and other accessories can be found from page 34 onwards

/// For deviating operating conditions please send us a written request stating the fluids, as well as the pressure and temperature range.

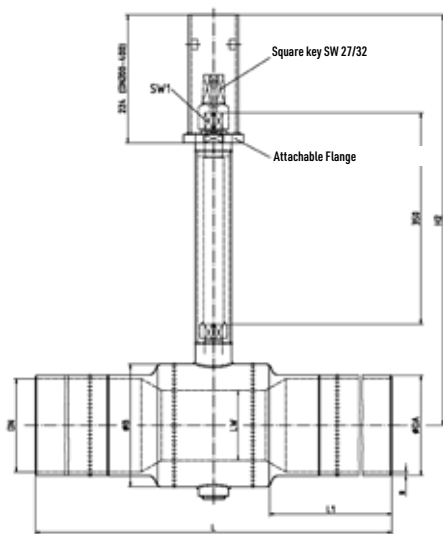

DN/LW [mm]	PN [bar]	DA [mm]	s* [mm]	L [mm]	L1 [mm]	B [mm]	H2 [mm]	SW 1 [mm]	Weight [kg]	Art.-No.
200/150	25	219.1	4.5	1500	648	254	725	32	100	076.0106
250/200	25	273.0	5.0	1500	625	324	760	32	140	076.0114
300/250	25	323.9	5.6	2000	817	407	900	32	380	076.0116
350/300	25	355.6	5.6	2000	769	508	942	32	645	076.0118
400/300	25	404.6	6.3	2000	770	508	942	32	680	076.0154

* The alignment of the wall thickness of the pipe end is carried out according to measurement „s“. The actual wall thicknesses used can be found in the table on page 42 of this catalogue.

BBF/KSF-R-HE

BALL VALVE WITH WELD ENDS FOR UNDERGROUND INSTALLATION



DN 450-1200 | PN 25

REDUCED BORE

INFORMATION

Ball Valve with Weld ends

/// Buried ball valves comply with the EN 488 standard

/// Suitable for the cold laying method

/// Operating temperature up to +150 °C

/// The trunnion mounted ball is standard

/// Underground ball valves are supplied unpainted as standard.

/// The angular gear and the square key are included in the delivery.

MATERIALS

Body Forged Steel / Steel

Weld Ends Steel

Ball Steel chemically nickel plated

Seat Rings PTFE

Stem Seals EPDM

OPTIONS

/// Suitable for steam

/// Additional extensions to adjust the overlap height (for version 2 and 3) in the lengths 350, 500, 750 and 1000 mm are available on request at short notice.

/// For deviating operating conditions please send us a written request stating the fluids, as well as the pressure and temperature range.

Version 1

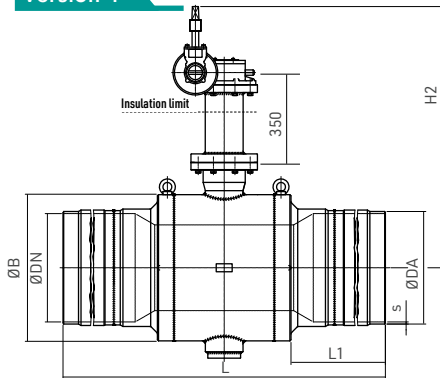

Version 2

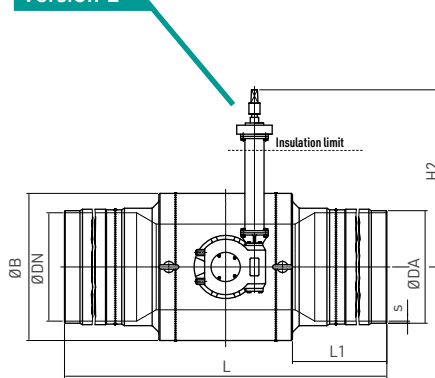

Version 3

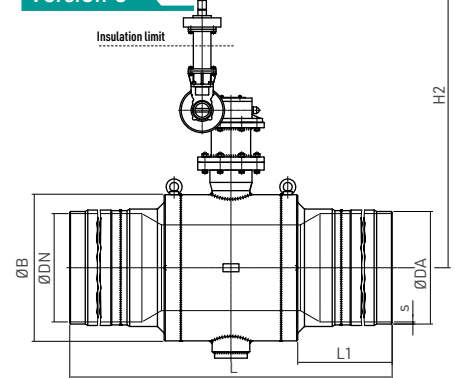

Version 1

H2 [mm]	Art.-No.	Version 2	Version 3
1121	a.A.	800	1368
1121	a.A.	800	1368
1256	a.A.	800	1445
a.A.	a.A.	a.A.	a.A.
a.A.	a.A.	a.A.	a.A.
a.A.	a.A.	a.A.	a.A.
a.A.	a.A.	a.A.	a.A.
a.A.	a.A.	a.A.	a.A.
a.A.	a.A.	a.A.	a.A.

Version 2

H2 [mm]	Art.-No.	Version 2	Version 3
800	a.A.	800	1368
800	a.A.	800	1368
800	a.A.	800	1445
a.A.	a.A.	a.A.	a.A.
a.A.	a.A.	a.A.	a.A.
a.A.	a.A.	a.A.	a.A.
a.A.	a.A.	a.A.	a.A.
a.A.	a.A.	a.A.	a.A.
a.A.	a.A.	a.A.	a.A.

Version 3

H2 [mm]	Art.-No.	Version 2	Version 3
1368	a.A.	800	1368
1368	a.A.	800	1368
1445	a.A.	800	1445
a.A.	a.A.	a.A.	a.A.
a.A.	a.A.	a.A.	a.A.
a.A.	a.A.	a.A.	a.A.
a.A.	a.A.	a.A.	a.A.
a.A.	a.A.	a.A.	a.A.
a.A.	a.A.	a.A.	a.A.

DN / LW [mm]	PN [bar]	DA [mm]	s* [mm]	L [mm]	L1 [mm]	B [mm]	Weight [kg]
450/400	25	457	6.3	2000	819	720	1120
500/400	25	508.0	6.3	2500	819	814	1400
600/500	25	610	7.1	1143	1140	955	2400
700/600	25	711	8.0	1295	1087	1116	ca. 3200
800/700	25	813	8.8	1397	1040	1261	ca. 4700
900/800	25	914	10	1499	1232	1396	ca. 6000
1000/900	25	1016	11	1800	a.A.	1561	ca. 7700
1200/1000	25	1220	12.5	2400	a.A.	1890	ca. 12000

* The alignment of the wall thickness of the pipe end is carried out according to measurement „s“. The actual wall thicknesses used can be found in the table on page 42 of this catalogue.

Ball Valves DN700 and above will be custom designed to meet order specifications. Please take note of the drawings submitted in case of an order.

BBF/ELF/ESF-V-HE



BALL VALVE FOR VENTING AND DRAINING WITH FLANGE AND WELD END

DN 25-100 | PN 25

FULL BORE



INFORMATION

Ball Valve for Venting and Draining with Flange and Weld end

/// Operating temperature up to +150 °C

/// Flanges drilled and sized in accordance with EN 1092 – Nominal Pressure PN25

MATERIALS

Body	Stainless Steel
Weld End	Steel
Flanges	Stainless Steel
Ball	Stainless Steel
Seat Rings	PTFE
Stem Seals	EPDM

OPTIONS

/// Suitable for steam

/// Further options for these ball valves are listed on page 37

/// For deviating operating conditions please send us a written request stating the fluids, as well as the pressure and temperature range.



Fully insulated draining and venting ball valves made of steel you can find on our website



To simplify the installation of the flange connection in confined spaces in road caps, we offer counter lugs as accessories. One counter lug replaces 2 nuts so that there is no need to hold the nuts underneath the flange connection. For more Information, please see page 35

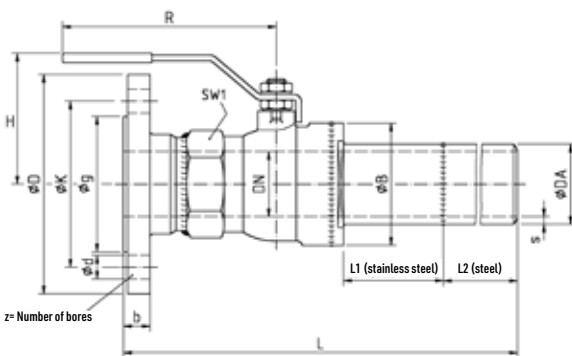

DN [mm]	PN [bar]	DA [mm]	s [mm]	L [mm]	L1 [mm]	L2 [mm]	D [mm]	B [mm]	H [mm]	R [mm]	SW 1 [mm]	Weight [kg]	Art.-No.
25	25	33.7	3.2	895	200	579	115	49	65	132	41	4.2	050.0004
32	25	42.4	3.2	1000	63	774	140	65	84	146	50	6.5	050.8241
40	25	48.3	3.2	963	50	771	150	75	85	146	55	8.5	050.0119
50	25	60.3	4.0	911	120	546	165	92	95	146	70	10.5	050.0120
80 ¹	25	88.9	4.0	1000	250	486	200	140	155	300	---	21.5	050.0198
100 ¹	25	114.3	3.6	1000	250	566	235	171	170	300	---	30.0	050.5050

¹The Body Material of this Version is 1.4571.



BBF/EMG/ESF-V-HE

BALL VALVE FOR VENTING AND DRAINING WITH THREAD AND WELD END

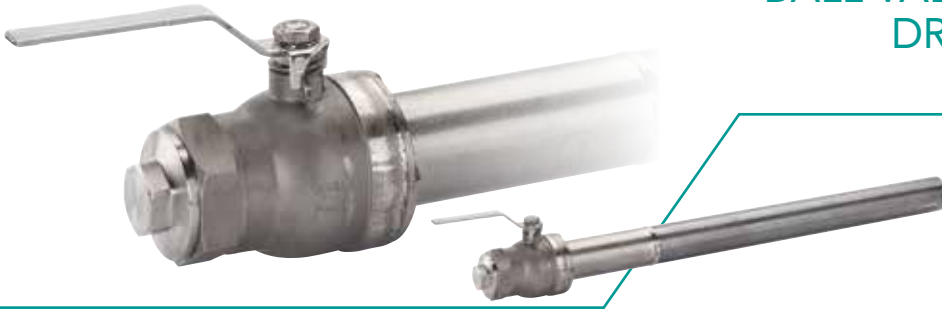

DN 25-50 | PN 25

FULL BORE

INFORMATION

Ball Valve for Venting and Draining with thread and Weld end

/// Operating temperature up to +150 °C

/// The sealing plug is included in the delivery.

MATERIALS

Body	Stainless Steel
Weld End	Steel
Ball	Stainless Steel
Sealing Plug	Stainless Steel
Seat Rings	PTFE
Stem Seals	EPDM

OPTIONS

/// Suitable for steam

/// For deviating operating conditions please send us a written request stating the fluids, as well as the pressure and temperature range.

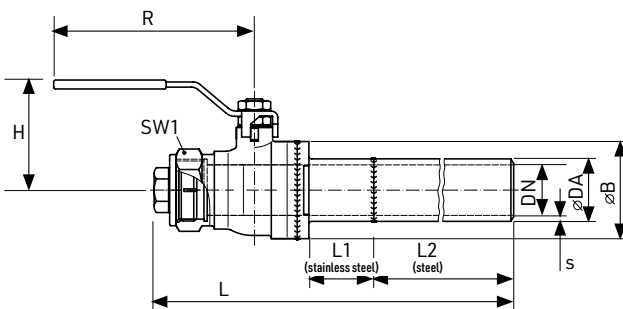

DN [mm]	PN [bar]	DA [mm]	s [mm]	L [mm]	L1 [mm]	L2 [mm]	B [mm]	H [mm]	R [mm]	SW1 [mm]	Weight [kg]	Art.-No.
25	40	33.7	3.2	1000	148	757	49	65	135	41	3.4	050.5617
32	40	42.4	3.2	1000	63	774	65	84	155	50	5.2	050.0065
40	40	48.3	3.2	941	50	771	75	85	155	55	6.2	050.0140
50	40	60.3	3.6	1000	151	711	92	95	155	70	7.4	050.2897

BBF/KSF-V-HE

TIE-IN BALL VALVE / BALL VALVE FOR ONE TIME OPERATION

DN 65-200 | PN 25

FULL BORE



INFORMATION

Tie-in Ball Valve / Ball Valve for one time operation

- /// Operating temperature up to +150 °C
- /// Delivery includes a cap for proper weld execution in accordance with "AGFW Arbeitsblatt FW401"
- /// The installation instructions (included in the delivery) must be followed!
- /// Stem design with double o-ring seals.
- /// supplied unpainted as standard
- /// Not suitable for autogenous welding

MATERIALS

Body	Forged Steel / Steel
Weld Ends	Steel
Ball	Stainless Steel
Seat Rings	PTFE
Stem Seals	EPDM

OPTIONS

- /// Suitable for steam
- /// For deviating operating conditions please send us a written request stating the fluids, as well as the pressure and temperature range.

For nominal diameters up to and including DN 50 please use our tapping ball valves (page 18)

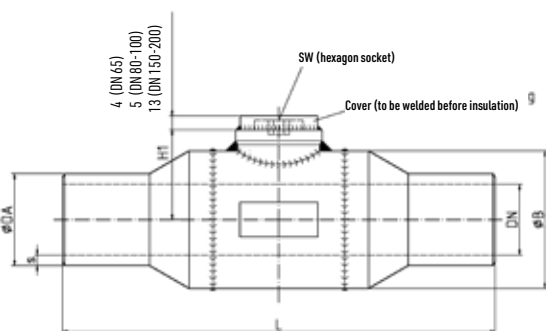

DN [mm]	PN [bar]	Da [mm]	s [mm]	L [mm]	B [mm]	H1 [mm]	SW 1 [mm]	Weight [kg]	Art.-No.
65	25	76.1	3.6	270	121	77.5	10	7.9	010.1113
80	25	88.9	4.0	280	140	100	12	9.7	010.1114
100	25	114.3	4.0	300	171	114	12	14.8	010.1147
125 ¹	25	139.7	4.5	350	203	149	22	26.5	010.9215
150 ¹	25	168.3	5.0	400	254	189	32	49.5	010.6078
200 ¹	25	219.1	6.3	460	324	223	32	84.0	010.2914

¹These ball valves are designed with an external square (SW1) on the selector shaft.

BBF/KSF-R-HE

TIE-IN BALL VALVE / BALL VALVE FOR ONE TIME OPERATION

DN 65-200 | PN 25

REDUCED BORE



INFORMATION

Tie-in Ball Valve / Ball Valve for one time operation

/// Operating temperature up to +150 °C

/// Delivery includes a cap for proper weld execution in accordance with "AGFW Arbeitsblatt FW401"

/// The installation instructions (included in the delivery) must be followed!

/// Stem design with double o-ring seals.

/// supplied unpainted as standard

/// Not suitable for autogenous welding

MATERIALS

Body Forged Steel / Steel

Weld Ends Steel

Ball Stainless Steel

Seat Rings PTFE

Stem Seals EPDM

OPTIONS

/// Suitable for steam

/// For deviating operating conditions please send us a written request stating the fluids, as well as the pressure and temperature range.

For nominal diameters up to and including DN 50 please use our tapping ball valves (page 18)

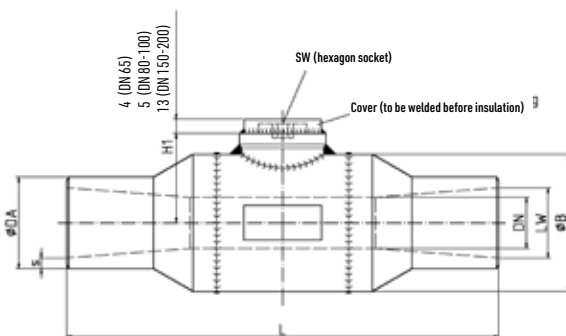

DN/LW [mm]	PN [bar]	Da [mm]	s [mm]	L [mm]	B [mm]	H1 [mm]	SW1 [mm]	Weight [kg]	Art.-No.
65/50	25	76.1	3.6	235	89	62.5	10	4.7	010.4196
80/65	25	88.9	4.0	265	121	77.5	10	7.9	010.4426
100/80	25	114.3	4.0	275	140	100	12	9.9	010.4427
125/100	25	139.7	4.5	300	171	114	12	17.5	010.5419
150/125 ¹	25	168.3	5.0	335	203	149	22	24.0	010.5425
200/150 ¹	25	219.1	6.3	375	254	189	32	48.0	010.2352

¹ These ball valves are designed with an external square (SW1) on the selector shaft.

BBF/KSF-V-HE

TAPPING BALL VALVE

DN 20-100 | PN 25

FULL BORE



INFORMATION

Tapping ball valve

- /// Operating temperature up to +150 °C
- /// Delivery includes a cap for proper weld execution in accordance with "AGFW Arbeitsblatt FW401"
- /// The installation instructions (included in the delivery) must be followed!
- /// Stem design with double o-ring seals.
- /// supplied unpainted as standard
- /// Not suitable for autogenous welding
- /// Suitable tapping system available at www.huetz-baumgarten.de. For further information, see page 39.

MATERIALS

Body	Forged Steel / Steel
Weld Ends	Steel
Ball	Stainless Steel
Seat Rings	PTFE
Stem Seals	EPDM

OPTIONS

- /// Suitable for steam
- /// For deviating operating conditions please send us a written request stating the fluids, as well as the pressure and temperature range.
- /// Larger nominal sizes available on request

Up to and including DN 50 also can be used as a disposable ball valve / tie in ball valve

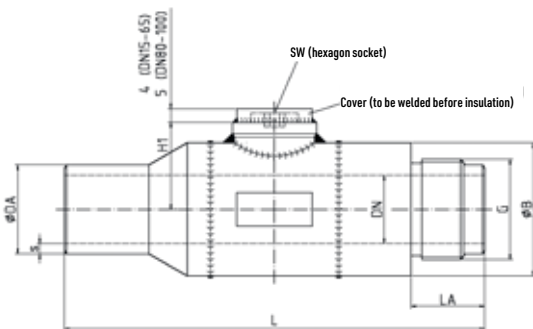

DN [mm]	PN [bar]	Da [mm]	s [mm]	L [mm]	B [mm]	LA [mm]	G	H1 [mm]	SW [mm]	Weight [kg]	Art.-No.
20	25	26.9	3.2	170	44	35	G 1 A	31.6	6	1.1	010.2892
25	25	33.7	3.2	180	54	35	G 1 ½ A	35	6	1.7	010.4272
32	25	42.4	3.2	200	63.5	35	G 1 ½ A	49.5	10	2.4	010.4276
40	25	48.3	3.2	210	76	55	G 2 ½ A	55	10	3.4	010.4283
50	25	60.3	3.6	240	90	55	G 2 ½ A	62.5	10	4.9	010.4295
65	25	76.1	3.6	260	121	55	G 2 ¾ A	77.5	10	8.2	010.4297
80	25	88.9	4.0	280	140	30	G 3 A	100	12	10.7	010.4417
100	25	114.3	4.0	300	171	30	G 4 A	114	12	16.6	010.4420



BALL VALVES FOR IN BUILDING APPLICATIONS



BBF/KSF-V-HS

BALL VALVE WITH WELD ENDS

DN 15-200 | PN 25

FULL BORE



INFORMATION

Ball Valve with Weld ends

/// Operating temperature up to +150 °C

/// Heating water version

From DN 125:

/// The trunnion mounted ball is standard

From DN 150:

/// We recommend the use of worm gear units (or planetary gear units up to max. DN400) for nominal sizes DN150 and larger.

MATERIALS

Body Forged Steel / Steel

Weld Ends Steel

Ball Stainless Steel

Seat Rings PTFE

Stem Seals EPDM

OPTIONS

/// Suitable for steam

/// Special lengths

/// Stem extensions 60mm resp. 100mm

/// Also available automated with electric or pneumatic actuators.

/// For deviating operating conditions please send us a written request stating the fluids, as well as the pressure and temperature range.

Not suitable for autogenous welding

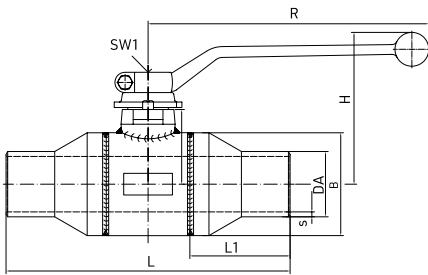

DN [mm]	PN [bar]	DA [mm]	s [mm]	L [mm]	L1 [mm]	B [mm]	H [mm]	R [mm]	SW1 [mm]	Gew. [kg]	Art.-No.
15	25	21,3	2,6	160	49	39	66	130	10	1,0	010.9120
20	25	26,9	3,2	160	47,5	44	69	130	10	1,3	010.9121
25	25	33,7	3,6	180	55	54	82	180	12	1,7	010.9122
32	25	42,4	3,6	200	70,1	63,5	110	205	16	2,6	010.9123
40	25	48,3	3,6	210	74,1	76	115	205	16	3,3	010.9124
50	25	60,3	3,6	250	80	89	125	205	16	4,6	010.7353
65	25	76,1	3,6	270	80	121	140	300	16	8,3	010.8514
80	25	88,9	4,0	280	78	140	160	350	22	11,5	010.3187
100	25	114,3	4,0	300	79	171	175	350	22	16,2	010.3188
125	25	139,7	4,5	350	90	203	195	500	22	27,0	010.3381
150	25	168,3	5,0	400	90	254	240	600	32	51,0	010.3348
200	25	219,1	6,3	460	96	324	275	600	32	82,5	010.2762

Suitable for autogenous welding, Ensure sufficient cooling of the housing body.

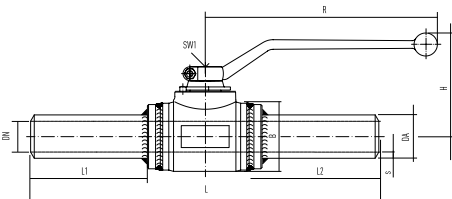

DN [mm]	PN [bar]	DA [mm]	s [mm]	L [mm]	L1 [mm]	B [mm]	H [mm]	R [mm]	SW1 [mm]	Gew. [kg]	Art.-No.
15	25	21,3	2,6	270	97	39	68	130	10	1,0	010.3233
20	25	26,9	3,2	270	97	44	70	130	10	1,3	010.2936
25	25	33,7	3,2	370	140	54	82	180	12	1,9	010.9350
32	25	42,4	3,2	370	145	64	110	205	16	2,8	010.9351
40	25	48,3	3,2	370	140	76	115	205	16	3,5	010.9352
50	25	60,3	3,6	500	205	89	125	205	16	5,0	010.9353
65	25	76,1	3,6	550	230	121	140	205	16	8,7	010.9354
80	25	88,9	4,0	550	213	140	160	350	22	12,0	010.9355
100	25	114,3	4,0	550	204	171	175	350	22	17,0	010.9356

Ball valves for autogenous welding are also suitable for the „pressing“ process. More detailed information on suitable pressing methods on request.



BBF/KSF-V-HS

BALL VALVE WITH WELD ENDS

DN 150-1200 | PN 25

FULL BORE

INFORMATION

Ball Valve with Weld ends

/// Operating temperature up to +150 °C

/// The trunnion mounted ball is standard

/// The worm gear with handwheel is included in the scope of delivery.

MATERIALS

Body	Forged Steel / Steel
Weld Ends	Steel
Ball	Stainless Steel; from DN 350: Steel chemically nickel plated
Seat Rings	PTFE
Stem Seals	EPDM

OPTIONS

/// Suitable for steam

/// Further options for these ball valves are listed on page 37

/// For deviating operating conditions please send us a written request stating the fluids, as well as the pressure and temperature range.

/// Also available automated with electric or pneumatic actuators.



On request, we can also supply this ball valve in a version with double shut-off, in accordance with DGUV 103-002.

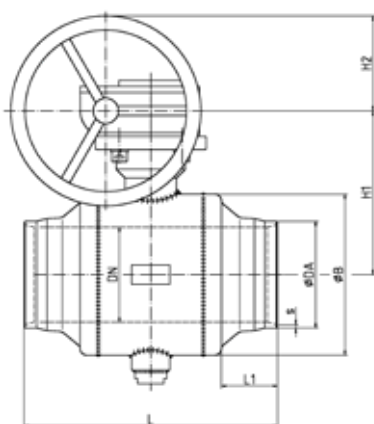

DN [mm]	PN [bar]	DA [mm]	s [mm]	L [mm]	L1 [mm]	B [mm]	H1 [mm]	H2 [mm]	Gew. [kg]	Art.-No.
150	25	168,3	5,0	400	90	254	349	150	90	075.0267
200	25	219,1	6,3	460	96	324	384	150	136	075.0268
250	25	273,0	7,1	540	90	407	355	200	290	075.0269
300	25	323,9	8,0	640	91	508	404	200	458	075.0270
350	25	355,6	8,0	680	86	559	431	200	608	a.A.
400	25	406,4	8,8	900	319	660	490	250	770	a.A.
450	25	457,0	6,3	950	158	720	567	200	ca.1300	a.A.
500	25	508,0	6,3	991	136	814	608	250	ca.1800	a.A.
600	25	610,0	7,1	1143	158	955	737	300	ca.2500	a.A.
700	25	711,0	8,0	1295	187	1116	870	300	ca.4000	a.A.
800	25	813,0	8,8	1397	430	1261	942	400	ca.4900	a.A.
900	25	914,0	10,0	1499	422	1396	1051	400	ca.7000	a.A.
1000	25	1016,0	11,0	1800	576	1561	1180	400	ca.9900	a.A.
1200	25	1220,0	12,5	2400	955	1890	1512	500	ca.18500	a.A.

Ball valves with a nominal diameter of DN350 and above are made to order in accordance with the customer's requirements. Please refer to the corresponding drawings in case of order.

BBF/KSF-R-HS

BALL VALVE WITH WELD ENDS

DN 65-200 | PN 25

REDUCED BORE



INFORMATION

Ball Valve with Weld ends

/// Operating temperature up to +150 °C

/// Heating water version

Ab DN 150:

/// The trunnion mounted ball is standard

Ab DN 200:

/// We recommend the use of worm gear units (or planetary gear units up to max. DN400) for nominal sizes DN200 and larger.

MATERIALS

Body Forged Steel / Steel

Weld Ends Steel

Ball Stainless Steel

Seat Rings PTFE

Stem Seals EPDM

OPTIONS

/// Suitable for steam

/// Special lengths

/// Stem extensions 60mm resp. 100mm

/// Also available automated with electric or pneumatic actuators.

/// For deviating operating conditions please send us a written request stating the fluids, as well as the pressure and temperature range.

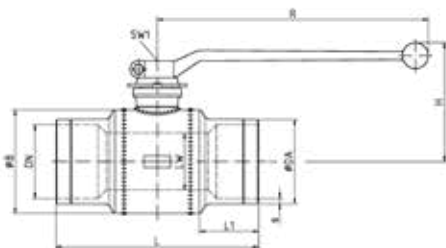

DN/LW [mm]	PN [bar]	Da [mm]	s [mm]	L [mm]	L1 [mm]	B [mm]	H [mm]	R [mm]	SW1 [mm]	Weight [kg]	Art-No.
65/50	25	76.1	3.6	235	70	89	125	205	16	5.2	010.3565
80/65	25	88.9	4.0	265	75	121	140	300	16	8.5	010.3563
100/80	25	114.3	4.0	275	80	140	160	350	22	12.1	010.9764
125/100	25	139.7	4.5	300	80	171	175	350	22	18.3	010.3564
150/125	25	168.3	5.0	335	85	203	195	500	22	28.0	010.6812
200/150	25	219.1	6.3	375	85	254	240	600	32	50.0	010.2349
250/200	25	273.0	7.1	450	100	324	275	600	32	83.0	010.6373



BBF/KSF-R-HS

BALL VALVE WITH WELD ENDS

DN 200-1200 | PN 25

REDUCED BORE

INFORMATION

Ball Valve with Weld ends

/// Operating temperature up to +150 °C

/// The trunnion mounted ball is standard

/// The worm gear with handwheel is included in the scope of delivery.

MATERIALS

Body	Forged Steel / Steel
Weld Ends	Steel
Ball	Stainless Steel; from DN 450: Steel chemically nickel plated
Seat Rings	PTFE
Stem Seals	EPDM

OPTIONS

/// Suitable for steam

/// Further options for these ball valves are listed on page 37

/// For deviating operating conditions please send us a written request stating the fluids, as well as the pressure and temperature range.

/// Also available automated with electric or pneumatic actuators.



On request, we can also supply this ball valve in a version with double shut-off, in accordance with DGUV 103-002.

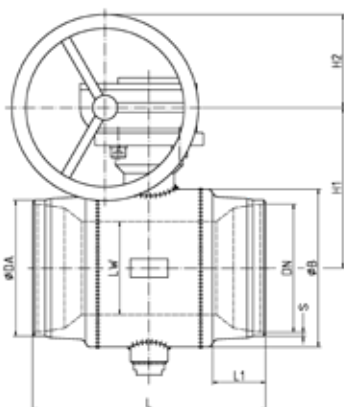

DN / LW [mm]	PN [bar]	Da [mm]	s [mm]	L [mm]	L1 [mm]	B [mm]	H1 [mm]	H2 [mm]	Weight [kg]	Art-No.
200/150	25	219.1	6.3	375	85	254	349	150	81	075.0260
250/200	25	273.0	7.1	450	98	324	384	150	101	075.0261
300/250	25	323.9	8.0	700	166	407	355	200	318	075.0262
350/300	25	355.6	8.0	800	170	508	404	200	513	075.0263
400/300	25	406.4	8.8	900	218	508	404	200	610	075.0264
450/400	25	457.0	10.0	950	195	660	490	200	833	a.A.
500/400	25	508.0	11.0	1000	318	660	490	200	885	a.A.
600/500	25	610.0	7.1	1143	212	820	608	250	2000	a.A.
700/600	25	711.0	8.0	1316	245	955	737	300	2700	a.A.
800/700	25	813.0	8.8	1346	213	1116	870	300	4300	a.A.
900/800	25	914.0	10.0	1727	596	1261	942	400	5200	a.A.
1000/900	25	1016.0	11.0	1800	572	1396	1051	400	7300	a.A.
1200/1000	25	1220.0	12.5	2800	1076	1561	1180	400	11400	a.A.

Ball valves with a nominal diameter of DN450 and above are made to order in accordance with the customer's requirements. Please refer to the corresponding drawings in case of order.

BBF/FSK-V-HS

BALL VALVE WITH FLANGES SHORT PATTERN



DN 32-200 | PN 25

FULL BORE

INFORMATION

Ball valve with flanges

/// Operating temperature up to +150 °C

/// Flange drilled and dimensioned according to EN 1092 - pressure rating PN 25. Observe pressure-temperature rating. Flange dimensions can be found on page 42.

From DN 125:

/// The trunnion mounted ball is standard

From DN 150:

/// Wir empfehlen ab der Nennweite DN150 die Verwendung von Schneckengetrieben.

MATERIALS

Body	Forged Steel / Steel
Flanges	Steel
Ball	Stainless Steel
Seat Rings	PTFE
Stem Seals	EPDM

OPTIONS

/// Suitable for steam

/// Further options for these ball valves are listed on page 37

/// For deviating operating conditions please send us a written request stating the fluids, as well as the pressure and temperature range.

/// On request, the ball valves are also available automated with electric or pneumatic actuators.

// Further pressure ratings available on request

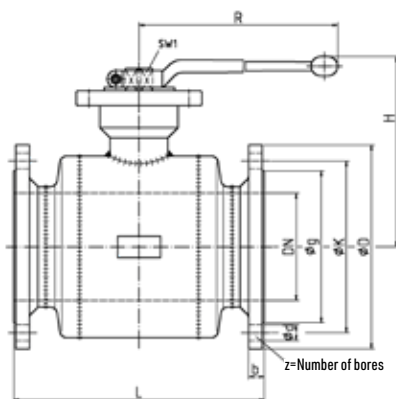

DN [mm]	PN [bar]	L [mm]	D [mm]	SW1 [mm]	R [mm]	H [mm]	Weight [kg]	Art.-No.
32	25	130	140	16	205	120	5.6	056.4686
40	25	140	150	16	205	125	6.9	056.9744
50	25	150	165	16	205	133	9.2	056.9450
65	25	170	185	16	300	137	12.2	056.1092
80	25	180	200	22	350	156	16.2	056.1094
100	25	190	235	22	350	170	21.1	056.2779
125	25	325	270	22	500	189	38.2	056.6910
150	25	350	300	32	600	229	61.5	056.4687
200	25	400	360	32	600	264	93.0	056.0465



BBF/FSK-V-HS

BALL VALVE WITH FLANGES SHORT PATTERN

DN 150-1000 | PN 25

FULL BORE

INFORMATION

Ball valve with flanges

/// Operating temperature up to +150 °C

/// Flange drilled and dimensioned according to EN 1092 - pressure rating PN 25. Observe pressure-temperature rating. Flange dimensions can be found on page 42.

/// The trunnion mounted ball is standard

/// The worm gear with handwheel is included in the scope of delivery.

MATERIALS

Body	Forged Steel / Steel
Flanges	Steel
Ball	Stainless Steel; from DN 350: Steel chemically nickel plated
Seat Rings	PTFE
Stem Seals	EPDM

OPTIONS

/// Suitable for steam

/// Further options for these ball valves are listed on page 37

/// For deviating operating conditions please send us a written request stating the fluids, as well as the pressure and temperature range.

/// Also available automated with electric or pneumatic actuators.

// Further pressure ratings available on request



On request, we can also supply this ball valve in a version with double shut-off, in accordance with DGVU 103-002.

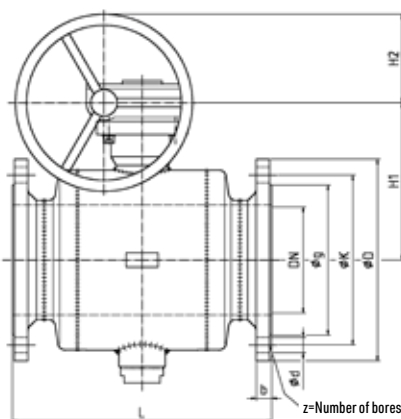

DN [mm]	PN [bar]	L [mm]	D [mm]	H1 [mm]	H2 [mm]	Weight [kg]	Art.-No.
150	25	350	300	349	150	76	075.0295
200	25	400	360	384	150	115	075.0298
250	25	650	425	355	200	286	075.0301
300	25	750	485	404	200	495	075.0304
350	25	850	555	431	200	660	a.A.
400	25	950	620	531	200	960	a.A.
450	25	a. A.	670	567	200	a. A.	a. A.
500	25	a. A.	730	608	250	a. A.	a. A.
600	25	a. A.	845	737	300	a. A.	a. A.
700	25	a. A.	960	870	300	a. A.	a. A.
800	25	a. A.	1085	942	400	a. A.	a. A.
900	25	a. A.	1185	1051	400	a. A.	a. A.
1000	25	a. A.	1320	1180	400	a. A.	a. A.

Ball valves with a nominal diameter of DN350 and above are made to order in accordance with the customer's requirements. Please refer to the corresponding drawings in case of order.

BBF/FSK-R-HS

BALL VALVE WITH FLANGES SHORT PATTERN

DN 65-250 | PN 25

REDUCED BORE



INFORMATION

Ball valve with flanges

/// Operating temperature up to +150 °C

/// Flange drilled and dimensioned according to EN 1092 - pressure rating PN 25. Observe pressure-temperature rating. Flange dimensions can be found on page 42.

From DN 150:

/// The trunnion mounted ball is standard

From DN 200:

/// We recommend the use of worm gears.

MATERIALS

Body	Forged Steel / Steel
Flanges	Steel
Ball	Stainless Steel
Seat Rings	PTFE
Stem Seals	EPDM

OPTIONS

/// Suitable for steam

/// Further options for these ball valves are listed on page 37

/// For deviating operating conditions please send us a written request stating the fluids, as well as the pressure and temperature range.

/// On request, the ball valves are also available automated with electric or pneumatic actuators.

// Further pressure ratings available on request

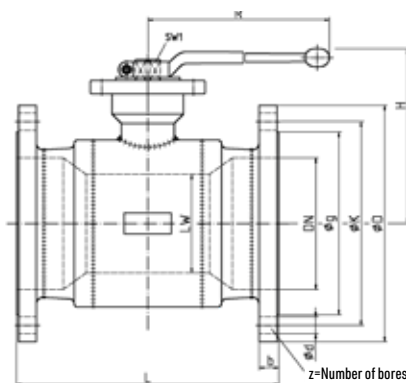

DN/LW [mm]	PN [bar]	L [mm]	D [mm]	SW1 [mm]	R [mm]	H [mm]	Weight [kg]	Art.-No.
65/50	25	170	185	16	205	133	11.1	056.7018
80/65	25	180	200	16	300	137	14.5	056.7017
100/80	25	190	235	22	350	156	19.7	056.7016
125/100	25	325	270	22	350	170	31.5	056.7015
150/125	25	350	300	22	500	189	45.0	056.7014
200/150	25	400	360	32	600	229	74.5	056.7013
250/200	25	450	425	32	600	264	117.0	056.7012



BBF/FSK-R-HS

BALL VALVE WITH FLANGES SHORT PATTERN

DN 200-1000 | PN 25

REDUCED BORE

INFORMATION

Ball valve with flanges

/// Operating temperature up to +150 °C

/// Flange drilled and dimensioned according to EN 1092 - pressure rating PN 25. Observe pressure-temperature rating. Flange dimensions can be found on page 42.

/// The trunnion mounted ball is standard

/// The worm gear with handwheel is included in the scope of delivery.

MATERIALS

Body	Forged Steel / Steel
Flanges	Steel
Ball	Stainless Steel; from DN 450: chemically nickel plated
Seat Rings	PTFE
Stem Seals	EPDM

OPTIONS

/// Suitable for steam

/// Further options for these ball valves are listed on page 37

/// For deviating operating conditions please send us a written request stating the fluids, as well as the pressure and temperature range.

/// Also available automated with electric or pneumatic actuators.

// Further pressure ratings available on request



On request, we can also supply this ball valve in a version with double shut-off, in accordance with DGUV 103-002.

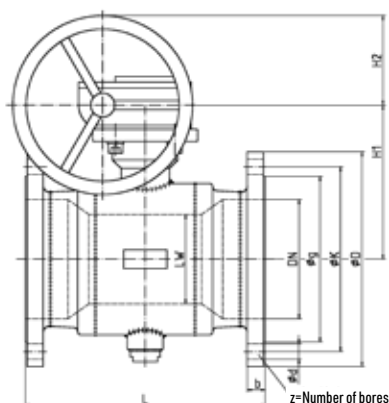

DN/LW [mm]	PN [bar]	L [mm]	D [mm]	H1 [mm]	H2 [mm]	Weight [kg]	Art.-No.
200/150	25	400	360	349	100	95	075.0274
250/200	25	450	425	384	150	148	075.0277
300/250	25	750	485	355	200	380	075.0280
350/300	25	850	555	404	200	610	075.0283
400/300	25	950	620	404	200	665	075.0286
450/400	25	1050	670	531	200	1010	a.A.
500/400	25	1150	730	531	200	1065	a.A.
600/500	25	a. A.	845	608	250	a. A.	a. A.
700/600	25	a. A.	960	737	300	a. A.	a. A.
800/700	25	a. A.	1085	870	300	a. A.	a. A.
900/800	25	a. A.	1185	946	400	a. A.	a. A.
1000/900	25	a. A.	1320	1051	400	a. A.	a. A.

Ball valves with a nominal diameter of DN450 and above are made to order in accordance with the customer's requirements. Please refer to the corresponding drawings in case of order.

BBF/FSL-V-HS

BALL VALVE WITH FLANGES LONG PATTERN



DN 15-100 | PN 25

FULL BORE

INFORMATION

Ball valve with flanges

/// Operating temperature up to +150 °C

/// Flange drilled and dimensioned according to EN 1092 - pressure rating PN 25. Observe pressure-temperature rating. Flange dimensions can be found on page 42.

MATERIALS

Body Forged Steel / Steel

Flanges Steel

Ball Stainless Steel

Seat Rings PTFE

Stem Seals EPDM

OPTIONS

/// Suitable for steam

/// Further options for these ball valves are listed on page 37

/// On request, the ball valves are also available automated with electric or pneumatic actuators.

/// For deviating operating conditions please send us a written request stating the fluids, as well as the pressure and temperature range.

// Further Sizes and pressure ratings available on request

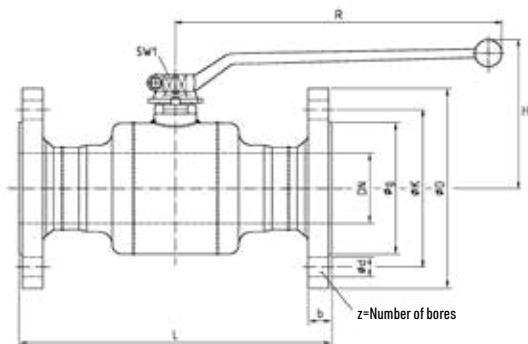

DN [mm]	PN [bar]	L [mm]	D [mm]	SW1 [mm]	R [mm]	H [mm]	Weight [kg]	Art.-No.
15	25	130	95	10	160	99	2.2	017.6145
20	25	150	105	10	160	102	3.0	017.3007
25	25	160	115	12	180	103	3.5	017.2924
32	25	180	140	16	205	120	7.0	017.2925
40	25	200	150	16	205	125	7.5	017.3238
50	25	230	165	16	205	133	11.0	017.3522
65	25	290	185	16	300	137	18.5	017.3645
80	25	310	200	22	350	156	27.0	017.0742
100	25	350	220	22	350	170	35.0	017.2803



BBF/FSK/KSF-V-HS FSL/KSF-V-HS

BALL VALVE FOR VENTING AND
DRAINING WITH FLANGE
AND WELD END

DN 15-150 | PN 25

FULL BORE

INFORMATION

Ball Valve with flange and weld end

/// Operating temperature up to +150 °C

/// From DN125 the trunnion mounted ball is standard

/// Flange drilled and dimensioned according to EN 1092 - pressure rating PN 25. Observe pressure-temperature rating. Flange dimensions can be found on page 42.

MATERIALS

Body	Forged Steel / Steel
Flansch	Steel
Schweißende	Steel
Ball	Stainless Steel
Seat Rings	PTFE
Stem Seals	EPDM

OPTIONS

/// Suitable for steam

/// Further options for these ball valves are listed on page 37

/// For deviating operating conditions please send us a written request stating the fluids, as well as the pressure and temperature range.

Not suitable for autogenous welding

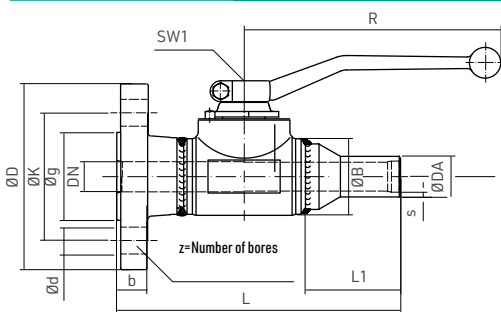

DN [mm]	PN [bar]	Da [mm]	s [mm]	L [mm]	L1 [mm]	B [mm]	D [mm]	R [mm]	SW1 [mm]	Weight [kg]	Art.-No.
15	25	21.3	2.6	145	49	39	95	130	10	1.7	050.9125
20	25	26.9	3.2	155	47.5	44	105	130	10	2.3	050.9126
25	25	33.7	3.2	170	55	54	115	180	12	3.1	050.9127
32	25	42.4	3.2	165	70.1	64	140	205	16	4.2	050.9128
40	25	48.3	3.2	175	74.1	76	150	205	16	5.2	050.9129
50	25	60.3	3.6	200	78	89	165	205	16	7.8	050.0143
65	25	76.1	3.6	280	80	121	185	300	16	11.6	050.0773
80	25	88.9	4.0	295	78	140	200	350	22	14.2	050.0732
100	25	114.3	4.0	325	80	171	235	350	22	21.9	050.0743
125	25	139.7	4.5	338	90	203	270	500	22	33.0	050.0753
150	25	168.3	5.0	375	90	254	300	600	32	58.0	050.1501

Suitable for autogenous welding, Ensure sufficient cooling of the housing body.

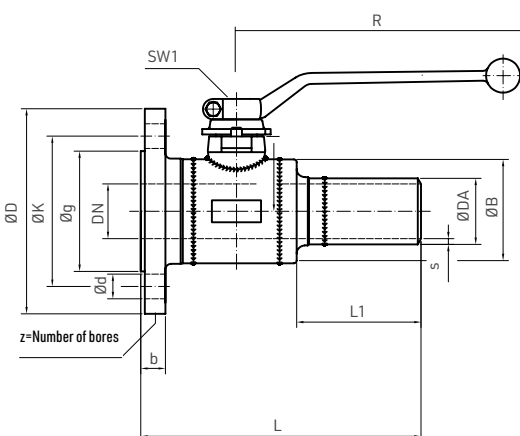

DN [mm]	PN [bar]	Da [mm]	s [mm]	L [mm]	L1 [mm]	B [mm]	D [mm]	R [mm]	SW1 [mm]	Weight [kg]	Art.-No.
15	25	21.3	2,6	200	104	39	95	130	10	1,7	050.0724
20	25	26,9	3,2	210	103	44	105	130	10	2,3	050.6489
25	25	33,7	3,2	215	100	54	115	180	12	3,1	050.9847
32	25	42,4	3,2	200	94	64	140	205	16	4,2	050.0141
40	25	48,3	3,2	205	91	76	150	205	16	5,2	050.0142

BBF/KSG/KSF-V-HS

BALL VALVE FOR VENTING AND DRAINING WITH THREAD AND WELD END



DN 15-50 | PN 25

FULL BORE

INFORMATION

Ball Valve with Thread and Weld end

/// Operating temperature up to +150 °C

/// The sealing plug is included in the delivery.

MATERIALS

Body	Forged Steel / Steel
Thread	Steel
Weld End	Steel
Sealing Cap	Brass
Ball	Stainless Steel
Seat Rings	PTFE
Stem Seals	EPDM

OPTIONS

/// Suitable for steam

/// Further options for these ball valves are listed on page 37

/// For deviating operating conditions please send us a written request stating the fluids, as well as the pressure and temperature range.

Not suitable for autogenous welding

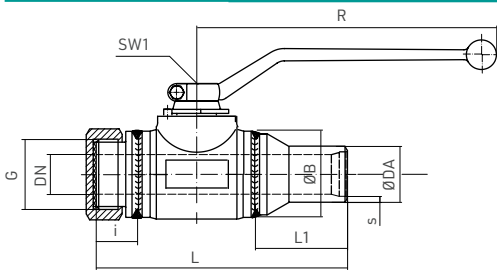

DN [mm]	PN [bar]	Da [mm]	s [mm]	L [mm]	L1 [mm]	i [mm]	G [mm]	B [mm]	R [mm]	SW1 [mm]	Weight [kg]	Art.-No.
15	25	21.3	2.6	132.5	49	23	G 3/4 A	39	130	10	1.2	050.9130
20	25	26.9	3.2	135	47.5	22.5	G 1 A	44	130	10	1.4	050.9131
25	25	33.7	3.6	150	55	25	G 1 1/4 A	54	179	12	1.7	050.9132
32	25	42.4	3.6	162	70.1	32.1	G 1 1/4 A	64	205	16	2.7	050.9133
40	25	48.3	3.6	172	74.1	36.1	G 1 1/2 A	76	205	16	3.5	050.9134
50	25	60.3	3.6	324	200	24	G 2 A	89	205	16	5.3	050.0214

Suitable for autogenous welding, Ensure sufficient cooling of the housing body.

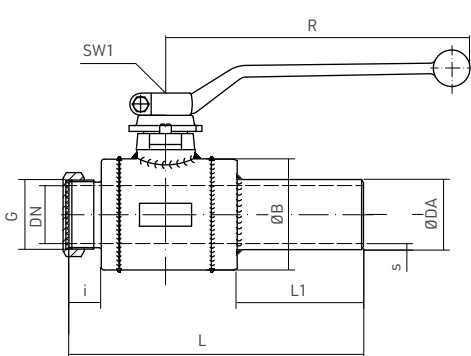

DN [mm]	PN [bar]	Da [mm]	s [mm]	L [mm]	L1 [mm]	i [mm]	G [mm]	B [mm]	R [mm]	SW1 [mm]	Weight [kg]	Art.-No.
15	25	21.3	2.6	291	200	14	G 3/4 A	39	130	10	1.1	050.5387
20	25	26.9	3.2	294	200	16	G 1 A	44	130	10	1.4	050.7214
25	25	33.7	3.2	245	140	18	G 1 1/4 A	54	180	12	1.7	050.8179
32	25	42.4	3.2	247	143	21	G 1 1/4 A	64	205	16	2.7	050.7360
40	25	48.3	3.2	251	137	22	G 1 1/2 A	76	205	16	3.5	050.6075

BBF/KSG-V-HS

BALL VALVE WITH THREADED ENDS



DN 16-50 | PN 25

FULL BORE

INFORMATION

Ball Valve with Threaded Ends

/// Operating temperature up to +150 °C

MATERIALS

Body	Forged Steel / Steel
Threads	Steel
Ball	Stainless Steel
Seat Rings	PTFE
Stem Seals	EPDM

OPTIONS

/// Suitable for steam

/// Further options for these ball valves are listed on page 37

/// For deviating operating conditions please send us a written request stating the fluids, as well as the pressure and temperature range.

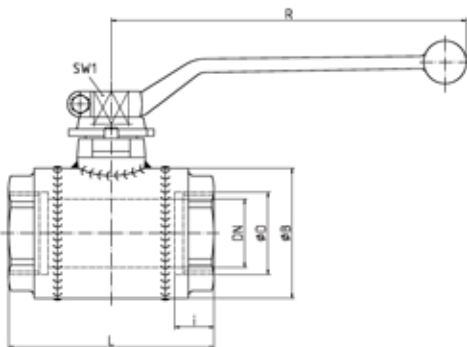

DN [mm]	PN [bar]	D [mm]	i [mm]	L [mm]	B [mm]	SW1 [mm]	R [mm]	Weight [kg]	Art.-No.
16	25	G 1/2	15	75	39	10	130	0.8	005.0003
20	25	G 3/4	18	80	44	10	130	0.9	005.0004
25	25	G 1	20	90	54	12	180	1.3	005.2782
32	25	G 1 1/4	21	110	64	16	205	2.2	005.2078
40	25	G 1 1/2	23	120	76	16	205	2.5	005.0060
50	25	G 2	24	140	89	16	205	3.5	005.3843

BBF/KSF-V-HS

TAPPING BALL VALVE FOR INDOOR INSTALLATION

DN 20-100 | PN 25

FULL BORE



INFORMATION

Hot Tapping Ball Valve with Weld Ends

/// Operating temperature up to +150 °C

/// Suitable tapping system available at www.huetz-baumgarten.de. For further information, see page 39.

MATERIALS

Body	Forged Steel / Steel
Weld Ends	Steel
Ball	Stainless Steel
Seat Rings	PTFE
Stem Seals	EPDM

OPTIONS

/// Suitable for steam

/// Further options for these ball valves are listed on page 37

/// For deviating operating conditions please send us a written request stating the fluids, as well as the pressure and temperature range.

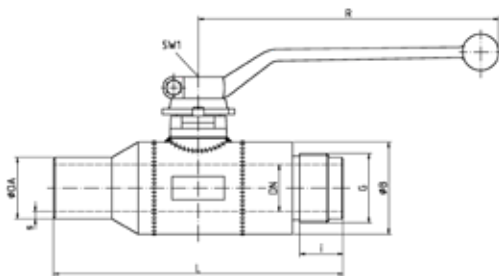

DN [mm]	PN [bar]	Da [mm]	s [mm]	L [mm]	i [mm]	G [mm]	B [mm]	R [mm]	SW1 [mm]	Weight [kg]	Art.-No.
20	25	26.9	3.2	170	35	G 1 A	44	130	10	1.2	010.0690
25	25	33.7	3.2	180	35	G 1½ A	54	180	12	1.8	010.0691
32	25	42.4	3.2	200	35	G 1½ A	64	205	16	2.6	010.0692
40	25	48.3	3.2	210	55	G 2½ A	76	205	16	3.6	010.0693
50	25	60.3	3.6	240	55	G 2½ A	90	205	16	5.1	010.0694
65	25	76.1	3.6	260	55	G 2¾ A	121	300	16	8.4	010.0695
80	25	88.9	4.0	280	30	G 3 A	140	350	22	10.9	010.0696
100	25	114.3	4.0	300	30	G 4 A	171	350	22	16.8	010.0697

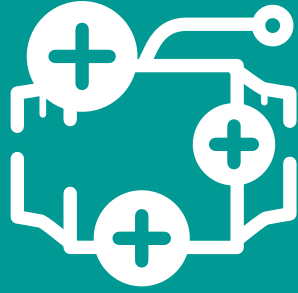

OPTIONS & ACCESSORIES

OPERATING ACCESSORIES FOR UNDERGROUND BALL VALVES

The accessories for Böhmer ball valves for underground installation are of modular design.

These accessories can only be assembled in one position. The two-flat connector serves as the base for additional extensions and attachable flanges and is always parallel to the axis of the pipeline.

Thanks also to the notch for the alignment pin in the square adapter, the position of the ball in every Böhmer ball valve for underground installation is always clearly visible on the top of the valve.

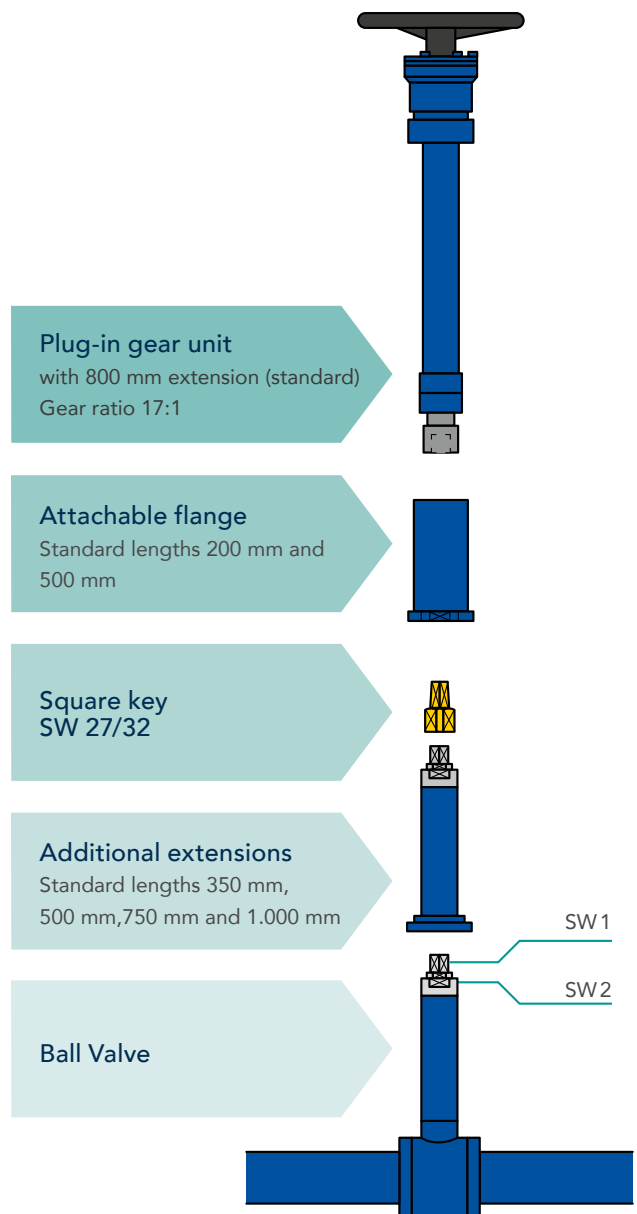

DN	DN	SW 1	SW 2	Attachable Flange L 200 mm	Attachable Flange L 500 mm	Square Key yellow	Additional Extension L 350 mm	Additional Extension L 500 mm	Additional Extension L 750 mm	Additional Extension L 1000 mm	Plug-in Gear Unit L 800 mm	T-Key
Full Bore	Reduced Bore	mm	mm	Art.-No. kg	Art.-No. kg	Art.-No. kg	Art.-No. kg	Art.-No. kg	Art.-No. kg	Art.-No. kg	Art.-No. kg	Art.-No. kg
20 - 65	25 - 80	16	40	075.7200 1,9	075.7201 4,8	628.2496 0,5	076.0736 2,5	076.0737 3,3	076.0729 4,7	076.0947 6,2		
80 - 125	100 - 150	22	50	075.7202 2,3	075.7203 4,9	628.2497 0,8	076.0682 4,5	076.0738 5,4	076.0739 7,5	076.0805 9,1	075.9999 18,4	316.9999 6,0
150 - 300	200 - 400	32	80	075.7204 3,1	075.7205 5,6	628.2498 1,4	076.0623 10,5	076.0740 12,5	076.0640 17,5	076.0720 22,0		

COUNTER FLAP

FOR SIMPLIFIED ASSEMBLY
OF FLANGE CONNECTIONS

DN 25-100 | PN 10 - 40



INFORMATION

Counter lugs for flange connections in directly buried drain and vent ball valves.

/// For simplified assembly of flange connections in directly buried pipeline construction, the counter lugs provide assistance for the assembly personnel.

/// The use of the counter lugs eliminates the need for counter-holding when bolting the flange connection, which is difficult due to limited space.

/// The counter brackets replace the need to hold the flange in place with tools by mutually securing 2 bolted connections.



MATERIAL

Stainless Steel

DN [mm]	Druckstufen				Anzahl pro Flanschverbindung	Art.-No.
	PN 10	PN 16	PN 25	PN 40		
25	X	X	X	X	2	050.9502
50	X	X	X	X	2	050.9500
80	X	X	X	X	4	050.9501
100			X	X	4	050.9504

STEM EXTENSION

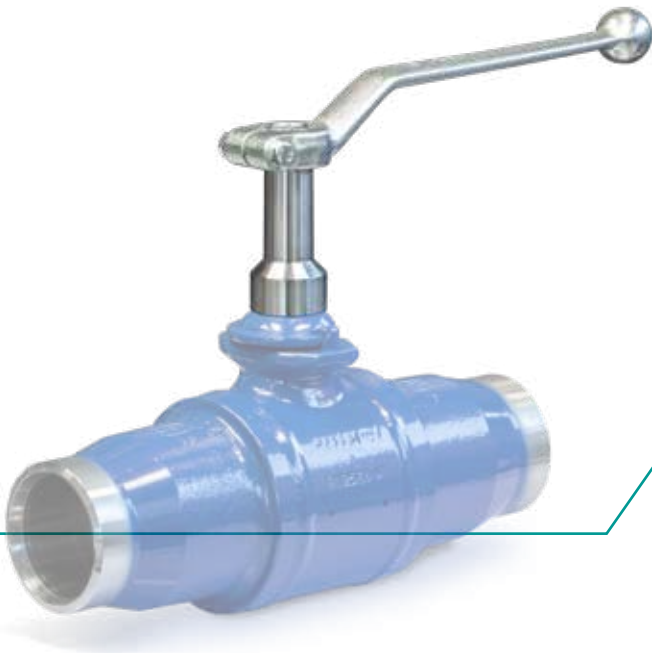

DN 15-200 FULL BORE /
DN 65-250 REDUCED BORE

INFORMATION

**Stem extension for use on ball valves
provided they are fitted with insulation.**

/// Stem extension only applicable for
Ball valves in Heating water version

/// The mounting screw is included in the
scope of delivery

MATERIALS

Stem Extension	Stainless Steel
Mounting Screw	Steel, galvanized

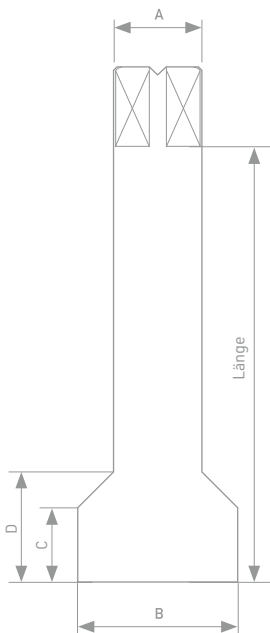

DN		Art.-No.		A [mm]	B [mm]	C [mm]	D [mm]
voll [mm]	reduziert [mm]	Länge 60 [mm]	Länge 100 [mm]				
15-20	15-25	050.3200	050.3204	12	22	11	16
25	32	050.3201	050.3205	15	22	12	16
32-65	40-80	050.3202	050.3206	20	31	15	21
80-125	100-150	050.3203	050.3207	28	45	24	33
150-200	200-250	---	050.3208	40	55	29	37

OPTIONS

	Underground Ball Valves HE					Standard Ball Valves HS						
	KSF V KSF R	ELF/ESF V	EMG/ESF V	KSF V KSF R Bedarfsanschluss-Kugelhahn	KSF V (Anbohrhahn)	KSF V KSF R	FSK V FSK R	FSL V	FSL/KSF V + FSK/KSF V FSL/KSF R + FSK/KSF R	KSG/KSF V	KSG V	KSF V (Anbohrhahn)
Special lengths	✓	✓	✓			✓		✓	✓	✓		
Variable stem extensions for underground installation ²	✓											
Stem extension 60 mm /100 mm						✓	✓	✓	✓	✓	✓	✓
Spigot for drain and vent ball valve	✓											
Test connection from DN150 (with plug or ball valve)						✓	✓	✓				
greater wall thicknesses for extreme axial loads or corrosion surcharges	✓											
With Flange/Weld end from DN125					✓							✓
Suitable for steam	✓			✓	✓	✓	✓	✓	✓	✓	✓	

²Variable spindle extensions for buried installation:

We recommend using additional extensions from our accessories list on to compensate for height differences.

Tender specification texts are available for download on our website.

ACTUATORS FOR BÖHMER DISTRICT HEATING BALL VALVES



Ball valves with worm gears

An economical solution for actuating large ball valves. You can find the available standard models on pages 29, 31, 33 and 35 in this catalogue.



Ball valves with screwed-on planetary gears

This ball valve actuator is distinguished by its compact design. Due to its minimal space requirement this model is perfectly suitable for demanding installation positions.



Pneumatic, hydraulic and electric ball valve actuators

BÖHMER ball valves can be combined with actuators made by all established actuator manufacturers. We look forward to receiving your technical inquiries.

DRILLING SYSTEM FOR BÖHMER DISTRICT HEATING BALL VALVES

BÖHMER and Hütz+Baumgarten – A strong partnership for maximum security when drilling ball valves into district heating pipelines.

Drilling system for BÖHMER district heating ball valves from DN 20 to DN 100.

This drilling system is optimally suited to our district heating ball valves and provides convincing proof of its absolute operational safety. This system is part of the professional production program of Hütz+Baumgarten.

The TÜV has tested the safety of this system and confirmed it by issuing type approval.

The drilling device is used to drill pipelines with a drilling dimension of up to DN 100 for BÖHMER district heating ball valves.

- // type approval TÜV A 297-13
- // for screwing on, including seals
- // for bore diameters from 17 mm up to 95 mm
- // for smooth boring rods with 13 mm diameter and 11 mm external square
- // maximum operating pressure = 20 bar
- // maximum operating temperature = 200°C
- // for manual and motor actuation

Further information available under www.huetz-baumgarten.de

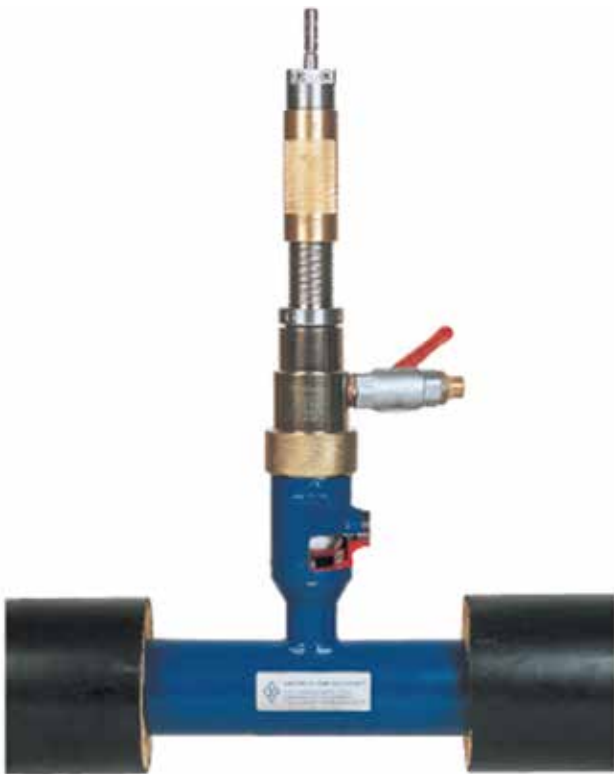

FURTHER DESIGNS OF BALL VALVES



Ball valve with insulation
Flange and weld
end up to DN 200



Ball valve with stem extension
Standard 60 and 100 mm
DN 10-250



Drain ball valve
Special surface coating for
outdoor service



Ball valve for venting and draining
Made of steel, fully insulated



Ball valves for installation in shafts
with drain and vent connectors



Ball valve for installation in shafts
with mounted planetary gear



Ball valve for underground installation
with adapter for mountable T-key



Ball valve for installation in shafts
with electric actuator



Ball valve for underground installation
in special design
with coaxial gearbox

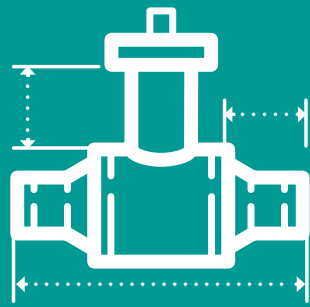

TECHNICAL DETAILS

TECHNICAL DETAILS

Wall thicknesses for ball valves for underground installation

The pipe ends used for BÖHMER inground district heating ball valves comply with the requirements of AD-Merkblatt B9 for the necking of pipes. Necking for drain and vent lines can be carried out on these pipes without falling below the minimum wall

thickness requirements of EN488. The following wall thicknesses refer to the pipe material used. These are machined at the weld preparation by wall thickness adjustment.

DN	20	25	32	40	50
Pipe Diameter	26,9 x 3,2	33,7 x 3,2	42,4 x 3,2	48,3 x 3,6	60,3 x 3,6
DN	65	80	100	125	150
Pipe Diameter	76,1 x 4,0	88,9 x 4,5	114,3 x 4,5	139,7 x 4,5	168,3 x 5,0
DN	200	250	300	350	400
Pipe Diameter	219,1 x 6,3	273,0 x 7,1	323,9 x 8,0	355,6 x 8,0	406,4 x 8,8

Flange dimensions

For all ball valves the standard for flange connections EN1092 is complied with. Below you will find an overview of the flange connection dimensions for pressure ratings PN10 - PN40, which were not listed in the data

sheets for reasons of clarity. The flange sheet thicknesses may deviate upwards from the dimensions required in the standard for manufacturing reasons.

DN	PN10	PN16	PN25	PN40	D	g	K	b	z	d
10	X	X	X	X	90	40	60	16	4	14
15	X	X	X	X	95	45	65	16	4	14
20	X	X	X	X	105	58	75	18	4	14
25	X	X	X	X	115	68	85	18	4	14
32	X	X	X	X	140	78	100	18	4	18
40	X	X	X	X	150	88	110	18	4	18
50	X	X	X	X	165	102	125	20	4	18
65	X	X			185	122	145	22	4	18
65			X	X	185	122	145	22	8	18
80	X	X	X	X	200	138	160	24	8	18
100	X	X			220	158	180	20	8	18
100			X	X	235	162	190	24	8	22
125	X	X			250	188	210	22	8	18
125			X	X	270	188	220	26	8	26
150	X	X			285	212	240	22	8	22
150			X	X	300	218	250	28	8	26
200	X				340	268	295	24	8	22
200		X			340	268	295	24	12	22
200			X		360	278	310	30	12	26
200				X	375	285	320	34	12	30
250	X				395	320	350	26	12	22
250		X			405	320	355	26	12	26
250			X		425	335	370	32	12	30
250				X	450	345	385	38	12	33
300	X				445	370	400	26	12	22
300		X			460	378	410	28	12	26
300			X		485	395	430	34	16	30
300				X	515	410	450	42	16	33
350	X				505	430	460	26	16	22
350		X			520	438	470	30	16	26
350			X		555	450	490	38	16	33
350				X	580	465	510	46	16	36
400	X				565	482	515	26	16	26
400		X			580	490	525	32	16	30
400			X		620	505	550	40	16	36
400				X	660	535	585	50	16	39

Permissible tensile and compressive forces

Diameter of the connecting pipe		Examples of pre-heated pipes and "cold-laid" pipes	
Full bore DN[mm]	reduced bore DN/LW [mm]	Tensile force at 130 K cooling [kN]	Compressive force at 130 K heating [kN]
20	20/16	26	41
25	25/50	37	60
32	32/25	53	86
40	40/32	61	99
50	50/40	85	139
65	65/50	109	177
80	80/65	140	228
100	100/80	204	332
125	125/100	251	480
150	150/125	337	547
200	200/150	495	804
250	250/200	686	1.116
300	300/250	913	1.484
350	350/300	1.004	1.632
400	400/300	1.291	2.098
450	450/400	1.454	2.364
500	500/400	1.619	2.423
600	600/500	2.192	3.087
700	700/600	2.880	3.926
800	800/700	3.624	4.761
900	900/800	4.629	6.144
1000	1000/900	5.661	7.439
1200	1200/1000	7.729	9.636

The permissible tensile and compressive forces in the adjacent table correspond to the figures required by EN 488. The permissible tensile and compression forces listed here are valid for all fully-welded BÖHMER district heating ball valves.

Ball valves for greater forces are also available on written request.

Drag coefficients

Full Bore			Reduced Bore		
DN	K_V [m ³ /h]	$\zeta(-)$	DN/LW	K_V [m ³ /h]	$\zeta(-)$
10-16	25	0.17	20/16	15	1.14
20	52	0.09	20/16	15	1.14
25	83	0.09	25/20	32	0.60
32	119	0.12	32/25	50	0.67
40	203	0.10	40/32	98	0.43
50	334	0.09	50/40	139	0.51
65	603	0.08	65/60	242	0.49
80	978	0.07	80/65	359	0.51
100	1.510	0.06	100/80	604	0.44
125	2.558	0.06	125/100	932	0.45
150	4.181	0.05	150/125	1.411	0.41
200	7.983	0.05	200/150	2.547	0.40
250	13.580	0.04	250/200	4.228	0.35
300	20.917	0.03	300/250	6.189	0.34
350	28.897	0.03	350/300	-	-
400	38.319	0.03	400/300	10.963	0.34
450	43.914	0.03	450/400	-	-
500	60.542	0.03	500/400	17.981	0.31
600	93.059	0.02	600/500	26.771	0.29
700	129.351	0.02	700/600	38.483	0.26
800	196.170	0.02	800/700	45.020	0.25
900	223.513	0.02	900/800	60.739	0.22
1000	283.612	0.02	1000/900	80.175	0.20
1200	439.598	0.01	1200/1000	82.375	0.22

The drag coefficients were determined for ball valves with solid balls.

Hollow balls cause more resistance and thus result in higher drag coefficients. In order to determine the exact losses, it is necessary to distinguish between trunnion-mounted and floating hollow balls.

Since the use of trunnion-mounted balls depends partly on the operating pressure, it is not possible to determine generally-valid drag coefficients for hollow balls as a function of nominal sizes.

The following are drag coefficients of butterfly valves based on approximate figures according to Dubbel:

DN 50: $\zeta=1.4$ $K_V=85$
 DN 200: $\zeta=0.8$ $K_V=1.790$
 DN 500: $\zeta=0.63$ $K_V=12.613$

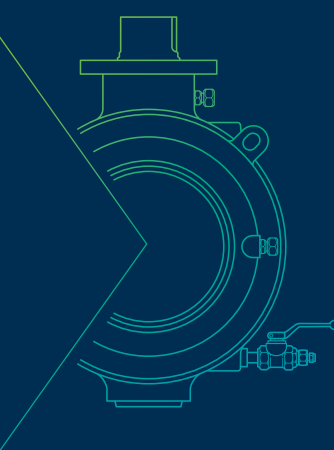

KUGELHÄHNE
BALL VALVES



BÖHMER GmbH

Gedulderweg 95
D-45549 Sprockhövel

☎ +49 2324 7001-0

✉ boehmer@boehmer.de

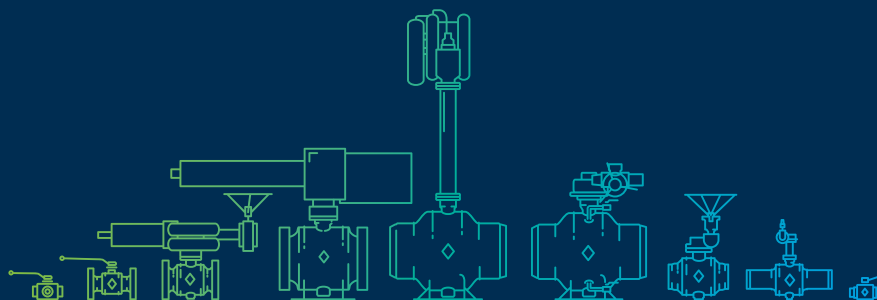

OUR EXPERIENCE – YOUR SAFETY

www.boehmer.de