

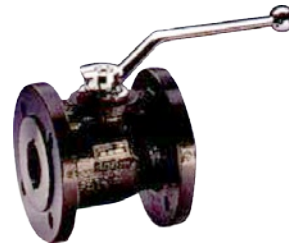

DN 65-200 ▲

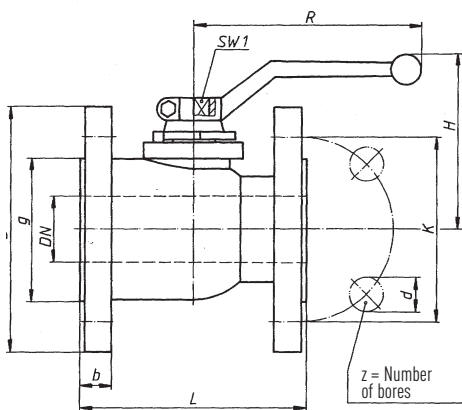

DN 32-50 ▲



Materials	PN	DN	
Body	10-40	32-200	Steel
		32-50	Steel, hard chromed
	10-25	65-200	Grey cast iron, hard chromed
		32-50	Steel, hard chromed
	40	65-100	Grey cast iron, hard chromed
		125-200	Spheroidal cast iron, hard chromed
Ball			
Seals	10-40	32-200	PTFE

Please quote order-no.:
FZK V XXX.XXX



- DN 32-50: one-piece body.
- DN 65-200: two-piece body.
- With DIN DVGW acceptance for gas.
- The handle is included; the use of a gear unit is required in case of difficult media up to DN 150.
- Ball valves with PTFE seals are normally delivered with FPM O-rings.
- Special designs upon requests.

Also available in Fire-Safe version with test certificate according to BS 6755 and/or with TÜV component approval

Flange dimensions DIN 2501 page 1	DN	PN	L	D	g	K	b	z	d	H	R	SW 1	Mass kg	Order-No.
PN 10 Flanged ends raised face*	32	10	130	140	78	100	18	4	18	125	205	16	6,7	FZK V 010.032
	40	10	140	150	88	110	18	4	18	130	205	16	8,1	FZK V 010.040
	50	10	150	165	102	125	20	4	18	138	205	16	10,6	FZK V 010.050
	65	10	170	185	122	145	20	4	18	146	300	16	18,5	FZK V 010.065
	80	10	180	200	138	160	22	8	18	160	350	22	24,5	FZK V 010.080
	100	10	190	220	158	180	22	8	18	175	350	22	29,0	FZK V 010.100
	125	10	325	250	188	210	22	8	18	195	500	22	49,0	FZK V 010.125
	150	10	350	285	212	240	22	8	22	240	600	32	68,0	FZK V 010.150
PN 16 Flanged ends raised face*	200	10	400	340	268	295	24	8	22	275	600	32	100,0	FZK V 010.200
	32	16	130	140	78	100	18	4	18	125	205	16	6,7	FZK V 016.032
	40	16	140	150	88	110	18	4	18	130	205	16	8,1	FZK V 016.040
	50	16	150	165	102	125	20	4	18	138	205	16	10,6	FZK V 016.050
	65	16	170	185	122	145	20	4	18	146	300	16	18,5	FZK V 016.065
	80	16	180	200	138	160	22	8	18	160	350	22	24,5	FZK V 016.080
	100	16	190	220	158	180	22	8	18	175	350	22	29,0	FZK V 016.100
	125	16	325	250	188	210	22	8	18	195	500	22	49,0	FZK V 016.125
PN 25 Flanged ends raised face*	150	16	350	285	212	240	22	8	22	240	600	32	68,0	FZK V 016.150
	200	16	400	340	268	295	24	12	22	275	600	32	100,0	FZK V 016.200
	32	25	130	140	78	100	18	4	18	125	205	16	6,7	FZK V 025.032
	40	25	140	150	88	110	18	4	18	130	205	16	8,1	FZK V 025.040
	50	25	150	165	102	125	20	4	18	138	205	16	10,6	FZK V 025.050
	65	25	170	185	122	145	22	8	18	146	300	16	18,5	FZK V 025.065
	80	25	180	200	138	160	24	8	18	160	350	22	24,5	FZK V 025.080
	100	25	190	235	162	190	24	8	22	175	350	22	33,0	FZK V 025.100
PN 40 Flanged ends raised face*	125	25	325	270	188	220	26	8	26	195	500	22	55,0	FZK V 025.125
	150	25	350	300	218	250	28	8	26	240	600	32	76,0	FZK V 025.150
	200	25	400	360	278	310	30	12	26	275	600	32	112,0	FZK V 025.200
	32	40	130	140	78	100	18	4	18	125	205	16	6,7	FZK V 040.032
	40	40	140	150	88	110	18	4	18	130	205	16	8,1	FZK V 040.040
	50	40	150	165	102	125	20	4	18	138	205	16	10,6	FZK V 040.050
	65	40	170	185	122	145	22	8	18	146	300	16	18,5	FZK V 040.065
	80	40	180	200	138	160	24	8	18	160	350	22	24,5	FZK V 040.080
PN 40 Flanged ends raised face*	100	40	190	235	162	190	24	8	22	175	350	22	33,0	FZK V 040.100
	125	40	325	270	188	220	26	8	26	195	500	22	55,0	FZK V 040.125
	150	40	350	300	218	250	28	8	26	240	600	32	76,0	FZK V 040.150
	200	40	400	375	285	320	34	12	30	275	600	32	120,0	FZK V 040.200

* Further types of flange gasket facings on demand