

3-Way Ball Valve Reduced Port, 1000 WOG, High Performance

KV-L50, KV-L51 (Direct Mount Type)

FEATURES:

- Investment Castings for Body and End Caps
- Various Thread Standards are Available
- Built-in ISO 5211 Direct Mounting Pad for Easy Automation
- Anti-Static Devices for Ball-Stem-Body
- Blow-out Proof Stem
- **TA-LUFT** Design Approved
- Positive Position Location At 90° Increments
- Locking in Every 90° Increments
- KV-L50: L-Port; KV-L51: T-Port
- Options: 1. Actuator 2. Limit Switch 3. Positioner

APPLICABLE STANDARDS:

- Design: MSS SP-110
- Wall Thickness: ASME B16.34 Class 400
- Pipe Thread: ASME B1.20.1, BS21
DIN 2999 / 259, ISO 228 / 1
JIS B 0203, ISO 7 / 1
- Inspection & Testing: MSS SP-110

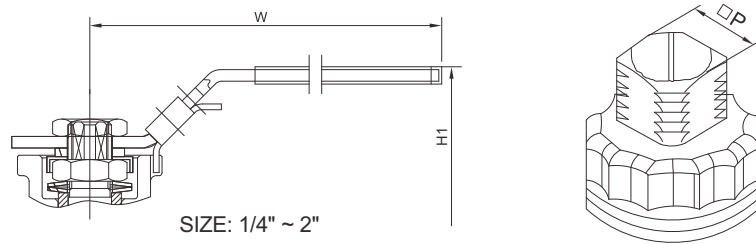
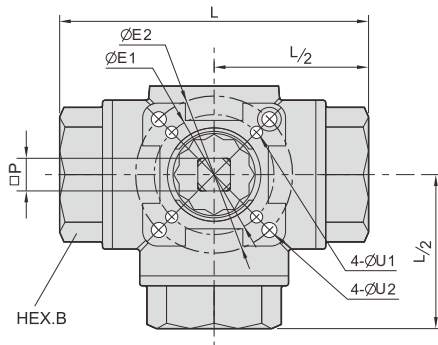

NO.	PART NAME	MATERIALS		
1	Body	CF8M	CF8	WCB
2	End Cap	CF8M	CF8	WCB
3	Ball	CF8M	CF8	
4	Ball Seat	TFM1600 / PTFE / RTFE		
5	Stem	316	304	
6	Anti-static Device	316	304	
7	Thrust Washer	PTFE		
8	O-ring	FKM		
9	Stem Packing	PTFE		
10	Bushing	50%SS + 50%PTFE		
11	Gland	316		
12	Belleville Washer	301		
13	Stem Nut	A194-8		
14	Stop-lock-cap	304		
15	Body Gasket	PTFE		
16	Hex Bolting	A193-B8		
17	Actuator	Pneumatic KP / Electric KQ		

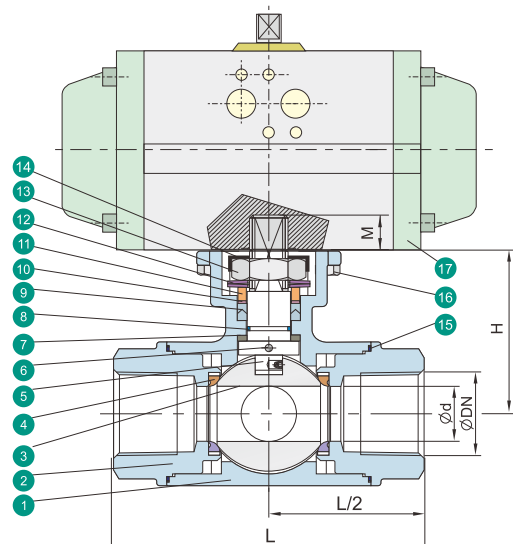

Unit: mm

SIZE	d	L	H	H1	W	M	E1	E2	U1	U2	P	HEX.B	ISO 5211
1/4"	11	79	42.0	70	147.0	9	36	42	6	6	9	27	F03-F04
3/8"	11	79	42.0	70	147.0	9	36	42	6	6	9	27	F03-F04
1/2"	11	79	42.0	70	147.0	9	36	42	6	6	9	27	F03-F04
3/4"	15	88	49.0	77	147.0	9	36	50	6	7	9	34	F03-F05
1"	20	108	59.5	87	176.5	11	42	50	6	7	11	41	F04-F05
1-1/4"	25	124	63.0	93	176.5	11	42	70	6	9	11	50	F04-F07
1-1/2"	32	135	73.5	103	215.0	14	50	70	7	9	14	56	F05-F07
2"	40	164	82.8	113	215.0	14	50	70	7	9	14	70	F05-F07