

ANSI - safety valve
Semi Nozzle (ANSI 150 - 300)

ARI-SAFE-SN ANSI
ANSI-Safety Relief Valve

- Type-test approved acc. to ASME Code Section VIII-Division 1.

- UV-stamp NB-stamp

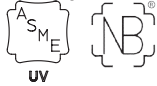

- Further approvals: see inside

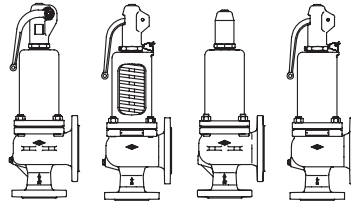

Fig. 901

902

911

912

Page 2

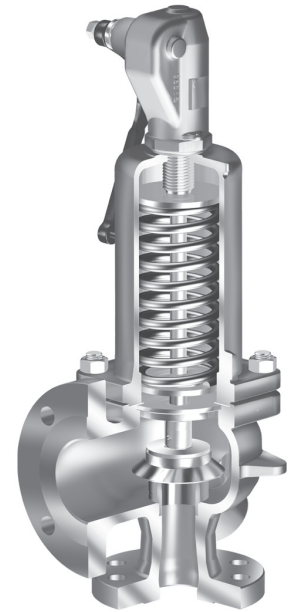

Fig. 900

ARI-SAFE-SN ANSI
Full lift safety valve D/G
Standard safety valve F

- Type-test approved acc. to DIN EN ISO 4126-1 / TRD 421 / AD2000-A2

- TÜV · SV · ... -663 · D/G Figure 901-912

- TÜV · SV · ... -663 · F Figure 901/911

- Further approvals: see inside

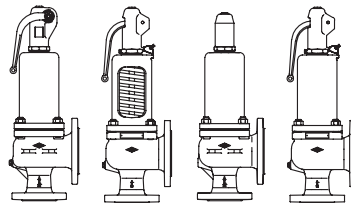

Fig. 901

902

911

912

Page 8

Features:

- Direct loaded with spring
- Wear resistant seat/disc
- Precision disc alignment and guide
- Possible with soft seal disc
- Possible with EPDM bellow
- Possible with stainless steel bellow

ARI-SAFE-SN ANSI (Semi-Nozzle) ANSI-Safety Relief Valve

Fig.901
closed lifting device,
closed bonnet

Fig.902
open lifting device,
open bonnet

Fig.911
gastight cap,
closed bonnet

Fig.912
open lifting device,
closed bonnet

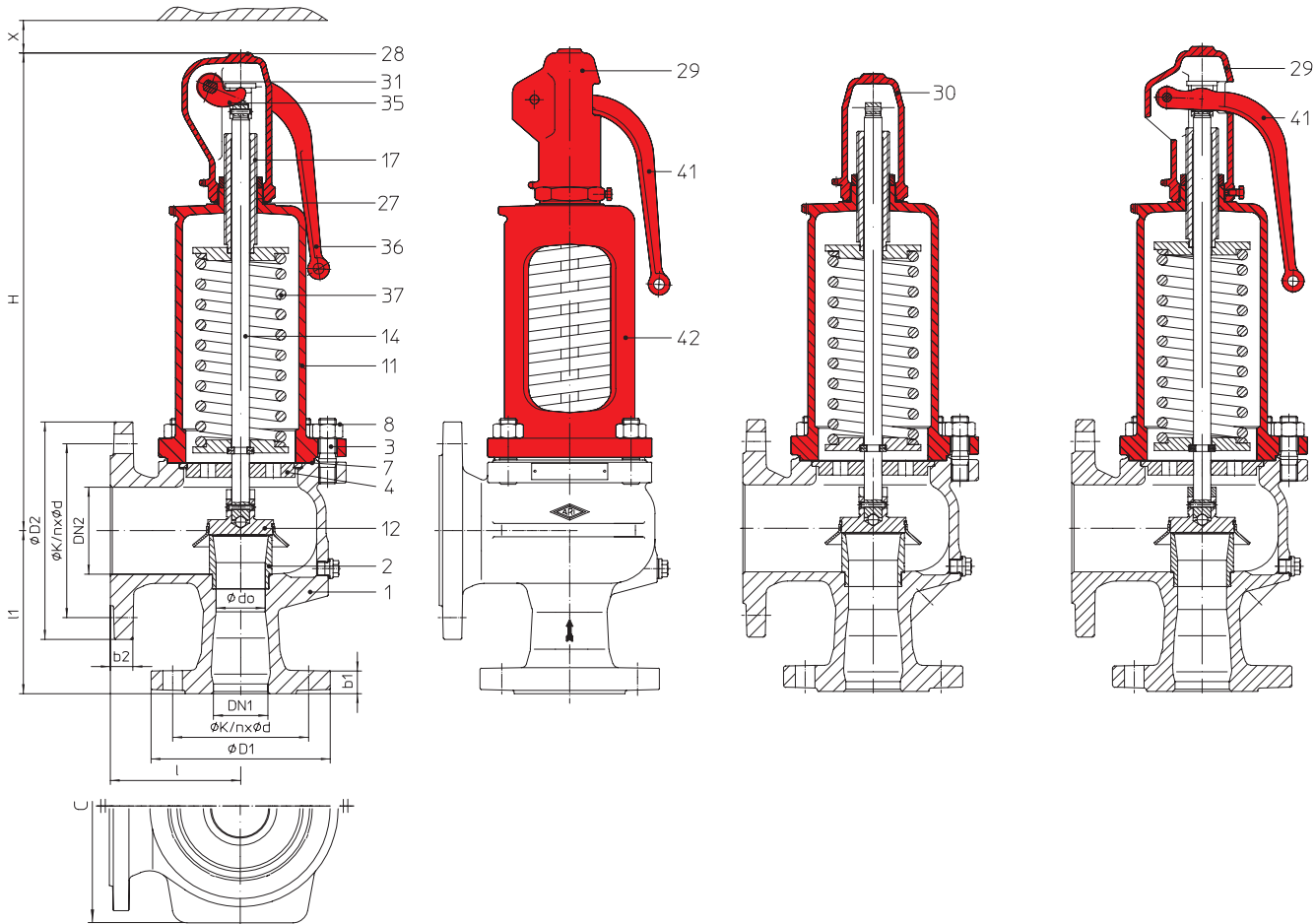
Figure	Nominal pressure	Material	Nominal diameter	Temperature range	Flange
32.901 / 902 / 911 / 912	ANSI150/150	SA216WCB	1" x 2" - 6" x 10"	-29°C to +427°C	ASME B16.5
35.901 / 902 / 911 / 912	ANSI300/150	SA216WCB	1" x 2" - 6" x 10"	-29°C to +427°C	ASME B16.5

Marking

 UV-stamp **UV**

NB-stamp

National Board Cert.-No.

Steam / Gas: 08008, 08031

Liquid: 08019, 08020

Construction / Application

Safety valve, spring loaded, direct loaded; gases, vapours and liquids

Requirement
ASME Code Section VIII-Division 1.
Sizing

Calculation acc. to API 520 (ASME VIII)

Details required

Medium: Gas Mass flow (kg/h), molar mass (kg/kmol), temperature (°C), set pressure (bar), back gauge pressure (bar)

 Medium: Liquid Mass flow (kg/h), density (kg/m³), viscosity, temperature (°C), set pressure (bar), back gauge pressure (bar)

Order data:

ARI-SAFE-SN ANSI - safety valve, Figure ..., Nominal diameter .../..., ANSI ..., Material ..., Set pressure ... bar

	standard: without metal bellow	optional: with metal bellow (refer to page 14)
Superimposed back pressure	no backpressure allowed	on request
Built up back pressure	max. 10% from set pressure (gauge) (higher on request)	on request

Parts			
Pos.	Sp.p.	Description	Fig. 32.901/902/911/912; 35.901/902/911/912
1		Body	SA216WCB
2		Seat	SA 479 Gr.316 Ti
3		Studs	SA 193 B7
4	x	Spindle guide	DN ≤ 2": SA276 Gr. 440; DN > 2": SA 395 / SA276 Gr. 440
7	x	Gasket	GRAPHIT/ SA182F321 (CrNi laminated with graphite)
8		Hexagon nut	SA 194 2H
11		Bonnet, closed	SA 395
12	x	Disc	SA276 Gr. 440
14	x	Spindle	SA276 Gr. 420
17		Adjusting screw	SA276 Gr. 420
27	x	Sealing ring	CuFA
28		Cap, closed	SA 395
29		Cap, open	SA 395
30		Cap, gastight	SA 395
31	x	Packing ring	GRAPHIT
35		Lift fork	SA 395
36		Lever, closed	SA 395
37	x	Spring	AISI 9254, AISI 6150
41		Lever, open	SA 395
42		Bonnet, open	SA 395
43		EPDM-Bellow (optional)	EPDM
55		Stainless steel bellow unit (optional)	SA 240 Gr. 316 Ti / SA 479 Gr. 316 Ti
70		Balanced piston (optional)	SA 240 Gr. 316 Ti
L Spare parts			

Certified coefficient of discharge K	UV-/NB-stamp							
NPS	1"x2"	1 1/2"x2" 1 1/2"x2 1/2"	1 1/2"x3"	2"x3"	3"x4"	4"x6"	6"x8"	6"x10"
Steam / Gas	< 2,05 barg: 0,769 / ≥ 2,05 barg: 0,817							
Liquid	> 1 bar: 0,615 (Slope)		> 1 barg: 0,545					

Seat tightness acc. to manufacturers standard better than API 527

Pressure-temperature-ratings			Intermediate values for max. permissible operational pressures can be determined by linear interpolation of the given temperature / pressure chart.									
acc. to ANSI			-29°C to 38°C	93°C	149°C	204°C	260°C	315°C	343°C	371°C	399°C	427°C
SA216WCB	ANSI150	(bar)	19,6	17,9	15,8	13,8	11,7	9,6	8,6	7,6	6,6	5,5
SA216WCB	ANSI300	(bar)	51,1	46,6	45,2	43,8	41,4	39,3	37,9	36,6	34,8	28,3

Information / restriction of technical rules need to be observed!

A production permission acc. to TRB 801 No. 45 is available.

The engineer, designing a system or a plant, is responsible for the selection of the correct valve.

Resistance and fitness must be verified (or contact the manufacturer for information).

NPS	1"x2"	1 1/2"x2"	1 1/2"x2 1 1/2"	1 1/2"x3"	2"x3"	3"x4"	4"x6"	4"x6"	6"x8"	6"x10"
-----	-------	-----------	--------------------	-----------	-------	-------	-------	-------	-------	--------

Center-to-face dimensions acc. to API 526 (dedicated to API-Orifice)											
API-Orifice		D, E	F	G	H	J	L	M	P	Q	R
I	(mm)	114,3	120,7	120,7	123,8	123,8	165,1	184,2	228,6	241,3	266,7
I1	(mm)	104,8	123,8	123,8	130,2	136,5	155,6	177,8	181	239,7	239,7

Dimensions												
d0	(mm)	18 ¹⁾	22,5 ²⁾	29	29	36	45	58,5	90	90	106	125
A0	(mm ²)	254 ¹⁾	398 ²⁾	661	661	1018	1590	2688	6362	6362	8825	12272
H	(mm)	280	330	330	390	435	545	690	690	845	890	
H (with stainless steel bellow)	(mm)	335	390	390	445	500	620	770	770	--	--	
X	(mm)	150	200	200	250	300	350	500		500	500	
C (Width of support tongues)	(mm)	--	--	--	--	204	280	332		362	408	

¹⁾ for steam / gas at set pressure 1 - 2 barg
²⁾ for steam / gas at set pressure 2,05 - 34 barg / Liquid at set pressure 1 - 34 barg

Weights											
Standard	(kg)	12	18	18	23	30	47	80	82	140	170
Option: stainless steel bellow	(kg)	13,5	20	20	25,5	34	54	90	92	--	--

Standard-flange dimensions											Flanges acc. to ASME / ANSI B16.5	
ØD1	ANSI150	(mm)	108	127	127	127	153	191	229		280	280
	ANSI300	(mm)	124	156	156	156	165	210	254		318	318
ØD2	ANSI150	(mm)	153	153	178	191	191	229	280		343	407
b1	ANSI150	(mm)	17,5	20,6	20,6	20,6	22,3	28,6	31,8		36,5	36,5
	ANSI300	(mm)	17,5	20,6	20,6	20,6	22,3	28,6	31,8		36,5	36,5
b2	ANSI150	(mm)	19,1	19,1	22,3	23,8	23,8	23,8	25,4		28,6	30,2

Standard-Flangeholes											
NPS			1"	1 1/2"	2"	2 1/2"	3"	4"	6"	8"	10"
ØK	ANSI150	(mm)	79	98	120,5	140	152,5	190,5	241,5	298,5	362
n x Ød		(mm)	4 x 16	4 x 16	4 x 19	4 x 19	4 x 19	8 x 19	8 x 22	8 x 22	12 x 25
ØK	ANSI300	(mm)	89	114,5	127	--	168	200	270	--	--
n x Ød		(mm)	4 x 19	4 x 22	8 x 19	--	8 x 22	8 x 22	12 x 22	--	--

NPS	1"x2"	1 1/2"x2" 1 1/2"x2 1/2"	1 1/2"x3"	2"x3"	3"x4"	4"x6"	6"x8"	6"x10"
-----	-------	----------------------------	-----------	-------	-------	-------	-------	--------

Spring ranges: Standard design									
Fig. 901902/911/912	(barg)	> 1,03 - 1,5	> 1,03 - 1,5	> 1,03 - 1,5	> 1,03 - 1,5	> 1,03 - 1,5	> 1,03 - 1,5	> 1,03 - 1,5	> 1,03 - 1,5
	(barg)	> 1,5 - 2	> 1,5 - 2	> 1,5 - 2	> 1,5 - 2	> 1,5 - 2	> 1,5 - 2	> 1,5 - 2	> 1,1 - 1,5
	(barg)	> 2 - 2,7	> 2 - 2,7	> 2 - 2,7	> 2 - 2,7	> 2 - 2,7	> 2 - 2,7	> 2 - 2,5	> 1,5 - 1,9
	(barg)	> 2,7 - 3,6	> 2,7 - 3,6	> 2,7 - 3,6	> 2,7 - 3,6	> 2,7 - 3,6	> 2,7 - 3,6	> 2,5 - 3	> 1,9 - 2,5
	(barg)	> 3,6 - 5	> 3,6 - 5	> 3,6 - 5	> 3,6 - 5	> 3,6 - 5	> 3,6 - 5	> 3 - 3,6	> 2,5 - 2,95
	(barg)	> 5 - 9	> 5 - 9	> 5 - 9	> 5 - 9	> 5 - 9	> 5 - 9	> 3,6 - 5	> 2,95 - 4
	(barg)	> 9 - 16	> 9 - 16	> 9 - 16	> 9 - 16	> 9 - 16	> 9 - 16	> 5 - 9	> 4 - 5,7
	(barg)	> 16 - 22	> 16 - 22	> 16 - 22	> 16 - 22	> 16 - 22	> 16 - 22	> 9 - 14	> 5,7 - 8,2
	(barg)	> 22 - 28	> 22 - 28	> 22 - 28	> 22 - 28	> 22 - 28	> 22 - 28	> 14 - 19	> 8,2 - 12
	(barg)	> 28 - 34	> 28 - 34	> 28 - 34	> 28 - 34				> 12 - 17
(barg)								> 17 - 24	
(barg)								> 24 - 27	

Spring ranges: Stainless steel bellow (optional)							
Fig. 901/911	(barg)	2,5 - 3,3	2,5 - 3,2	2,6 - 3,6	2,8 - 3,4	2,5 - 3,7	2,5 - 3,5
	(barg)	> 3,3 - 4,6	> 3,2 - 4	> 3,6 - 4,5	> 3,4 - 4,5	> 3,7 - 4,6	> 3,5 - 4,2
	(barg)	> 4,6 - 5,4	> 4 - 5,5	> 4,5 - 5,6	> 4,5 - 8,4	> 4,6 - 5,9	> 4,2 - 4,9
	(barg)	> 5,4 - 7	> 5,5 - 6,4	> 5,6 - 7,5	> 8,4 - 10	> 5,9 - 8	> 4,9 - 5,6
	(barg)	> 7 - 9	> 6,4 - 7,9	> 7,5 - 10	> 10 - 11,5	> 8 - 10	> 5,6 - 7
	(barg)	> 9 - 11,7	> 7,9 - 11,5	> 10 - 12,5	> 11,5 - 16	> 10 - 18	> 7 - 8
	(barg)	> 11,7 - 16	> 11,5 - 18,5	> 12,5 - 16	> 16 - 18,5		> 8 - 9,3
	(barg)	> 16 - 22	> 18,5 - 25	> 16 - 22	> 18,5 - 23		> 9,3 - 11,5
(barg)	> 22 - 30					> 11,5 - 13	

Capacity saturated steam incl. 10% overpressure

NPS		1"x2" ²⁾	1 1/2"x2"	1 1/2"x2 1/2"	1 1/2"x3"	2"x3"	3"x4"	4"x6"	6"x8"	6"x10"
Set pressure		Saturated steam kg/h								
1 ¹⁾	(barg)	228	593	593	914	1428	2413	5712	7923	11018
1,5 ¹⁾	(barg)	279	727	727	1120	1749	2956	6997	9706	13496
2 ¹⁾	(barg)	331	860	860	1325	2070	3499	8282	11488	15975
2,05	(barg)	556	923	923	1422	2221	3755	8886	12326	17140
2,5	(barg)	643	1067	1067	1644	2567	4339	10271	14247	19813
3	(barg)	737	1222	1222	1884	2943	4973	11772	16328	22708
3,5	(barg)	830	1378	1378	2124	3318	5607	13273	18410	25603
4	(barg)	924	1534	1534	2364	3693	6241	14774	20492	28498
4,5	(barg)	1018	1690	1690	2604	4068	6876	16274	22574	31394
5	(barg)	1112	1846	1846	2844	4443	7510	17775	24656	34289
6	(barg)	1300	2158	2158	3325	5194	8778	20777	28820	40079
7	(barg)	1488	2469	2469	3805	5944	10046	23779	32983	45870
8	(barg)	1676	2781	2781	4286	6694	11314	26781	37147	51660
9	(barg)	1863	3093	3093	4766	7445	12582	29782	41311	57451
10	(barg)	2051	3404	3404	5246	8195	13850	32784	45474	63241
11	(barg)	2239	3716	3716	5727	8946	15119	35786	49638	69032
12	(barg)	2427	4028	4028	6207	9696	16387	38788	53802	74822
13	(barg)	2615	4340	4340	6687	10446	17655	41789	57965	80612
14	(barg)	2803	4651	4651	7168	11197	18923	44791	62129	86403
15	(barg)	2990	4963	4963	7648	11947	20191	47793	66293	92193
16	(barg)	3178	5275	5275	8128	12697	21459	50795	70456	97984
17	(barg)	3366	5586	5586	8609	13448	22728	53797	74620	103774
18	(barg)	3554	5898	5898	9089	14198	23996	56798	78784	109565
19	(barg)	3742	6210	6210	9569	14948	25264	59800	82947	115355
20	(barg)	3929	6522	6522	10050	15699	26532		87111	121146
21	(barg)	4117	6833	6833	10530	16449	27800		91275	126936
22	(barg)	4305	7145	7145	11011	17200	29068		95439	
24	(barg)	4681	7768	7768	11971	18700	31605		103766	
26	(barg)	5056	8392	8392	12932	20201	34141		112093	
27	(barg)	5244	8704	8704	13412	20951	35409		116257	
28	(barg)	5432	9015	9015	13893	21702	36677			
30	(barg)	5808	9639	9639	14853	23203				
32	(barg)	6183	10262	10262	15814	24703				
34	(barg)	6559	10886	10886	16775	26204				

1) Capacity below 2,05 barg set pressure are calculated with 0,21 barg overpressure.

2) NPS 1" x 2" set pressure 1 to 2 barg: do = 18 mm / set pressure > 2 barg: do = 22,5 mm

Capacity Air incl. 10% Drucksteigerung

NPS		1"x2" ²⁾	1 1/2"x2"	1 1/2"x2 1/2"	1 1/2"x3"	2"x3"	3"x4"	4"x6"	6"x8"	6"x10"
Set pressure		Air in Nm ³ /h (0°C; 1,013 bara)								
1 ¹⁾	(barg)	296	770	770	1186	1853	3132	7413	10283	14299
1,5 ¹⁾	(barg)	362	943	943	1453	2269	3836	9080	12596	17516
2 ¹⁾	(barg)	429	1117	1117	1720	2686	4541	10748	14909	20732
2,05	(barg)	725	1205	1205	1855	2898	4899	11596	16085	22368
2,5	(barg)	834	1385	1385	2133	3332	5633	13332	18493	25716
3	(barg)	956	1588	1588	2445	3819	6456	15280	21196	29475
3,5	(barg)	1078	1790	1790	2757	4306	7279	17229	23899	33234
4	(barg)	1200	1992	1992	3069	4793	8103	19177	26602	36992
4,5	(barg)	1322	2195	2195	3380	5280	8926	21126	29305	40751
5	(barg)	1443	2397	2397	3692	5767	9749	23074	32008	44510
6	(barg)	1687	2802	2802	4316	6741	11396	26972	37413	52027
7	(barg)	1931	3207	3207	4939	7715	13042	30869	42819	59544
8	(barg)	2175	3612	3612	5563	8689	14689	34766	48225	67062
9	(barg)	2419	4017	4017	6187	9663	16335	38663	53631	74579
10	(barg)	2662	4422	4422	6810	10637	17982	42560	59037	82096
11	(barg)	2906	4827	4827	7434	11611	19629	46457	64443	89614
12	(barg)	3150	5232	5232	8057	12585	21275	50354	69849	97131
13	(barg)	3394	5637	5637	8681	13559	22922	54251	75254	104648
14	(barg)	3638	6041	6041	9304	14533	24568	58148	80660	112166
15	(barg)	3881	6446	6446	9928	15506	26215	62046	86066	119683
16	(barg)	4125	6851	6851	10552	16480	27861	65943	91472	127200
17	(barg)	4369	7256	7256	11175	17454	29508	69840	96878	134718
18	(barg)	4613	7661	7661	11799	18482	31154	73737	102284	142235
19	(barg)	4857	8066	8066	12422	19402	32801	77634	107690	149753
20	(barg)	5100	8471	8471	13046	20376	34448		113095	157270
21	(barg)	5344	8876	8876	13670	21350	36094		118501	164787
22	(barg)	5588	9281	9281	14293	22324	37741		123907	
24	(barg)	6076	10091	10091	15540	24272	41034		134719	
26	(barg)	6563	10900	10900	16788	26220	44327		145531	
27	(barg)	6807	11305	11305	17411	27194	45974		150936	
28	(barg)	7051	11710	11710	18035	28168	47620			
30	(barg)	7538	12520	12520	19282	30116				
32	(barg)	8026	13330	13330	20529	32064				
34	(barg)	8514	14140	14140	21776	34012				

¹⁾ Capacity below 2,05 barg set pressure are calculated with 0,21 barg overpressure.

²⁾ NPS 1" x 2" set pressure 1 to 2 barg: do = 18 mm / set pressure > 2 barg: do = 22,5 mm

Capacity water incl. 10% overpressure

NPS		1"x2"	1 1/2"x2"	1 1/2"x2 1/2"	1 1/2"x3"	2"x3"	3"x4"	4"x6"	6"x8"	6"x10"
Set pressure		Water m ³ /h								
1 ¹⁾	(barg)	14	20	20	31	49	82	194	269	374
1,5 ¹⁾	(barg)	16	24	24	37	58	97	231	320	445
2 ¹⁾	(barg)	18	27	27	42	65	111	262	363	505
2,5	(barg)	21	30	30	47	73	124	293	406	565
3	(barg)	23	33	33	51	80	136	321	445	619
3,5	(barg)	24	36	36	55	87	146	347	481	669
4	(barg)	26	38	38	59	93	157	370	514	715
4,5	(barg)	28	41	41	63	98	166	393	545	758
5	(barg)	29	43	43	66	104	175	414	575	799
6	(barg)	32	47	47	73	113	192	454	629	875
7	(barg)	35	51	51	78	123	207	490	680	945
8	(barg)	37	54	54	84	131	221	524	727	1011
9	(barg)	39	58	58	89	139	235	556	771	1072
10	(barg)	41	61	61	94	146	247	586	813	1130
11	(barg)	43	64	64	98	154	260	614	852	1185
12	(barg)	45	67	67	103	160	271	642	890	1238
13	(barg)	47	69	69	107	167	282	668	926	1288
14	(barg)	49	72	72	111	173	293	693	961	1337
15	(barg)	51	75	75	115	179	303	717	995	1384
16	(barg)	52	77	77	119	185	313	741	1028	1429
17	(barg)	54	79	79	122	191	323	764	1059	1473
18	(barg)	55	82	82	126	196	332	786	1090	1516
19	(barg)	57	84	84	129	202	341	807	1120	1558
20	(barg)	58	86	86	133	207	350		1149	1598
21	(barg)	60	88	88	136	212	359		1177	1637
22	(barg)	61	90	90	139	217	367		1205	
24	(barg)	64	94	94	145	227	383		1259	
26	(barg)	67	98	98	151	236	399		1310	
27	(barg)	68	100	100	154	241	407		1335	
28	(barg)	69	102	102	157	245	414			
30	(barg)	72	105	105	162	254				
32	(barg)	74	109	109	168	262				
34	(barg)	76	112	112	173	270				

¹⁾ Capacity below 2,05 barg set pressure are calculated with 0,21 barg overpressure.

ARI-SAFE-SN ANSI (Semi-Nozzle) - Full lift safety valve D/G, Standard safety valve F

Fig. ... 901
 closed lifting device,
 closed bonnet

Fig. ... 902
 open lifting device,
 open bonnet

Fig. ... 911
 gastight cap,
 closed bonnet

Fig. ... 912
 open lifting device,
 closed bonnet

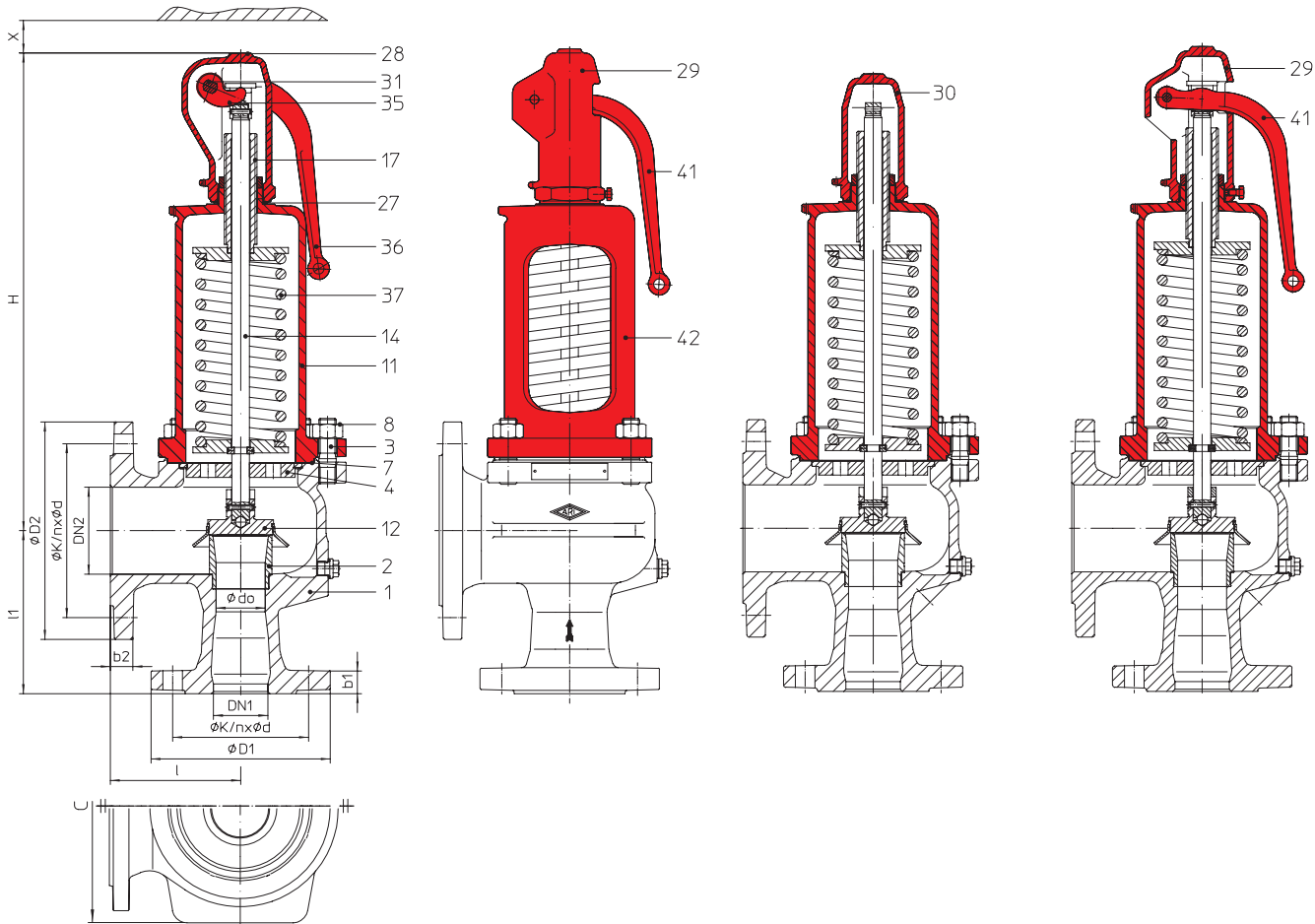
Figure	Nominal pressure	Material	Nominal diameter	Temperature range	Flange
32.901 / 902 / 911 / 912	ANSI150/150	SA216WCB	1" x 2" - 6" x 10"	-29°C to +427°C	ASME B16.5
35.901 / 902 / 911 / 912	ANSI300/150	SA216WCB	1" x 2" - 6" x 10"	-29°C to +427°C	ASME B16.5

Type-test approval

Full lift safety valve: (acc. to VdTÜV-leaflet 663)	Fig. 901/902/911/912	TÜV · SV · . . -663 · D/G (Standard valve 0,2-0,5 bar)
Standard safety valve:	Fig. 901/911	TÜV · SV · . . -663 · F (NPS 1" x 2" - 6" x 10")

Construction / Application

Safety valve, spring loaded, direct loaded; steam, gases, vapours and liquids

Requirement
Acc. to DIN EN ISO 4126-1 / TRD 421 / AD2000-A2
Sizing

Calculation acc. to EN ISO 4126-1, TRD 421 and AD-leaflet A2

Details required

Medium: Gas	Mass flow (kg/h), molar mass (kg/kmol), temperature (°C), set pressure (bar), back gauge pressure (bar)
Medium: Liquid	Mass flow (kg/h), density (kg/m ³), viscosity, temperature (°C), set pressure (bar), back gauge pressure (bar)

Order data:

ARI-SAFE-SN ANSI - safety valve, Figure ..., Nominal diameter .../..., ANSI ..., Material ..., Set pressure ... bar

	standard: without metal bellow	optional: with metal bellow (refer to page 14)
Superimposed back pressure	no backpressure allowed	on request
Built up back pressure	max. 10% from set pressure (gauge) (higher on request)	on request

Parts			
Pos.	Sp.p.	Description	Fig. 32.901/902/911/912; 35.901/902/911/912
1		Body	SA216WCB
2		Seat	SA 479 Gr.316 Ti
3		Studs	SA 193 B7
4	x	Spindle guide	DN ≤ 2": SA276 Gr. 440; DN > 2": SA 395 / SA276 Gr. 440
7	x	Gasket	GRAPHIT/ SA182F321 (CrNi laminated with graphite)
8		Hexagon nut	SA 194 2H
11		Bonnet, closed	SA 395
12	x	Disc	SA276 Gr. 440
14	x	Spindle	SA276 Gr. 420
17		Adjusting screw	SA276 Gr. 420
27	x	Sealing ring	CuFA
28		Cap, closed	SA 395
29		Cap, open	SA 395
30		Cap, gastight	SA 395
31	x	Packing ring	GRAPHIT
35		Lift fork	SA 395
36		Lever, closed	SA 395
37	x	Spring	AISI 9254, AISI 6150
41		Lever, open	SA 395
42		Bonnet, open	SA 395
43		EPDM-Bellow (optional)	EPDM
55		Stainless steel bellow unit (optional)	SA 240 Gr. 316 Ti / SA 479 Gr. 316 Ti
70		Balanced piston (optional)	SA 240 Gr. 316 Ti
L Spare parts			

Coefficient of discharge Kdr		VdTÜV (without UV-/NB-stamp) (Values for D/G variabel: 1" - 4" < 3,5 bar, 6" < 4,0 bar)							
NPS		1"x2"	1 1/2"x2" 1 1/2"x2 1/2"	1 1/2"x3"	2"x3"	3"x4"	4"x6"	6"x8"	6"x10"
TÜV · SV · ... -663 · D/G	(bar)	0,74						0,70	
TÜV · SV · ... -663 · F	(bar)	0,54			0,48		0,45		

Seat tightness acc. to manufacturers standard better than API 527

Pressure-temperature-ratings			Intermediate values for max. permissible operational pressures can be determined by linear interpolation of the given temperature / pressure chart.									
acc. to ANSI			-29°C to 38°C	93°C	149°C	204°C	260°C	315°C	343°C	371°C	399°C	427°C
SA216WCB	ANSI150	(bar)	19,6	17,9	15,8	13,8	11,7	9,6	8,6	7,6	6,6	5,5
SA216WCB	ANSI300	(bar)	51,1	46,6	45,2	43,8	41,4	39,3	37,9	36,6	34,8	28,3

Information / restriction of technical rules need to be observed!

A production permission acc. to TRB 801 No. 45 is available.

The engineer, designing a system or a plant, is responsible for the selection of the correct valve.

Resistance and fitness must be verified (or contact the manufacturer for information).

NPS	1"x2"	1 1/2"x2"	1 1/2"x2 1/2"	1 1/2"x3"	2"x3"	3"x4"	4"x6"	4"x6"	6"x8"	6"x10"
-----	-------	-----------	------------------	-----------	-------	-------	-------	-------	-------	--------

Center-to-face dimensions acc. to API 526 (dedicated to API-Orifice)											
API-Orifice		D, E	F	G	H	J	L	M	P	Q	R
I	(mm)	114,3	120,7	120,7	123,8	123,8	165,1	184,2	228,6	241,3	266,7
I1	(mm)	104,8	123,8	123,8	130,2	136,5	155,6	177,8	181	239,7	239,7

Dimensions											
d0	(mm)	22,5	29	29	36	45	58,5	90	90	106	125
A0	(mm ²)	398	661	661	1018	1590	2688	6362	6362	8825	12272
H	(mm)	280	330	330	390	435	545	690	690	845	890
H (with stainless steel bellow)	(mm)	335	390	390	445	500	620	770	770	--	--
X	(mm)	150	200	200	250	300	350	500		500	500
C (Width of support tongues)	(mm)	--	--	--	--	204	280	332		362	408

Weights											
Standard	(kg)	12	18	18	23	30	47	80	82	140	170
Option: stainless steel bellow	(kg)	13,5	20	20	25,5	34	54	90	92	--	--

Standard-flange dimensions											
											Flanges acc. to ASME / ANSI B16.5
ØD1	ANSI150	(mm)	108	127	127	127	153	191	229	280	280
	ANSI300	(mm)	124	156	156	156	165	210	254	318	318
ØD2	ANSI150	(mm)	153	153	178	191	191	229	280	343	407
	ANSI300	(mm)	17,5	20,6	20,6	20,6	22,3	28,6	31,8	36,5	36,5
b1	ANSI150	(mm)	17,5	20,6	20,6	20,6	22,3	28,6	31,8	36,5	36,5
	ANSI300	(mm)	17,5	20,6	20,6	20,6	22,3	28,6	31,8	36,5	36,5
b2	ANSI150	(mm)	19,1	19,1	22,3	23,8	23,8	23,8	25,4	28,6	30,2

Standard-Flangeholes											
NPS		1"	1 1/2"	2"	2 1/2"	3"	4"	6"	8"	10"	
ØK	ANSI150	(mm)	79	98	120,5	140	152,5	190,5	241,5	298,5	362
n x Ød	ANSI150	(mm)	4 x 16	4 x 16	4 x 19	4 x 19	4 x 19	8 x 19	8 x 22	8 x 22	12 x 25
ØK	ANSI300	(mm)	89	114,5	127	--	168	200	270	--	--
n x Ød	ANSI300	(mm)	4 x 19	4 x 22	8 x 19	--	8 x 22	8 x 22	12 x 22	--	--

NPS	1"x2"	1 1/2"x2" 1 1/2"x2 1/2"	1 1/2"x3"	2"x3"	3"x4"	4"x6"	6"x8"	6"x10"
-----	-------	----------------------------	-----------	-------	-------	-------	-------	--------

Spring ranges: Standard design									
Full lift safety valve Fig. 901902/911/912	(barg)	0,2 - 0,5	0,2 - 0,5	0,2 - 0,5	0,2 - 0,5	0,2 - 0,5	0,2 - 0,5	0,2 - 0,4	0,2 - 0,5
	(barg)	> 0,5 - 1	> 0,5 - 1	> 0,5 - 1	> 0,5 - 1	> 0,5 - 1	> 0,5 - 1	> 0,4 - 0,75	> 0,5 - 1
	(barg)	> 1 - 1,5	> 1 - 1,5	> 1 - 1,5	> 1 - 1,5	> 1 - 1,5	> 1 - 1,5	> 0,75 - 1,1	> 1 - 1,5
	(barg)	> 1,5 - 2	> 1,5 - 2	> 1,5 - 2	> 1,5 - 2	> 1,5 - 2	> 1,5 - 2	> 1,1 - 1,5	> 1,5 - 1,9
	(barg)	> 2 - 2,7	> 2 - 2,7	> 2 - 2,7	> 2 - 2,7	> 2 - 2,7	> 2 - 2,5	> 1,5 - 1,9	> 1,9 - 2,3
	(barg)	> 2,7 - 3,6	> 2,7 - 3,6	> 2,7 - 3,6	> 2,7 - 3,6	> 2,7 - 3,6	> 2,5 - 3	> 1,9 - 2,5	> 2,3 - 2,7
	(barg)	> 3,6 - 5	> 3,6 - 5	> 3,6 - 5	> 3,6 - 5	> 3,6 - 5	> 3 - 3,6	> 2,5 - 2,95	> 2,7 - 3,3
	(barg)	> 5 - 9	> 5 - 9	> 5 - 9	> 5 - 9	> 5 - 9	> 3,6 - 5	> 2,95 - 4	> 3,3 - 4,1
	(barg)	> 9 - 16	> 9 - 16	> 9 - 16	> 9 - 16	> 9 - 16	> 5 - 9	> 4 - 5,7	> 4,1 - 5,5
	(barg)	> 16 - 22	> 16 - 22	> 16 - 22	> 16 - 22	> 16 - 22	> 9 - 14	> 5,7 - 8,2	> 5,5 - 7,4
	(barg)	> 22 - 28	> 22 - 28	> 22 - 28	> 22 - 28	> 22 - 28	> 14 - 19	> 8,2 - 12	> 7,4 - 11
	(barg)	> 28 - 34	> 28 - 34	> 28 - 34	> 28 - 34		> 19 - 24	> 12 - 17	> 11 - 16
	(barg)	> 34 - 40	> 34 - 40	> 34 - 40	> 34 - 40			> 17 - 24	> 16 - 21
	(barg)							> 24 - 27	> 21 - 26

Spring ranges: Stainless steel bellow (optional)									
Standard safety valve Fig. 901/911	(barg)	2,5 - 3,3	2,5 - 3,2	2,6 - 3,6	2,8 - 3,4	2,5 - 3,7	2,5 - 3,5		
	(barg)	> 3,3 - 4,6	> 3,3 - 4	> 3,6 - 4,5	> 3,4 - 4,5	> 3,7 - 4,6	> 3,5 - 4,2		
	(barg)	> 4,6 - 5,4	> 4 - 5,5	> 4,5 - 5,6	> 4,5 - 8,4	> 4,6 - 5,9	> 4,2 - 4,9		
	(barg)	> 5,4 - 7	> 5,5 - 6,4	> 5,6 - 7,5	> 8,4 - 10	> 5,9 - 8	> 4,9 - 5,6		
	(barg)	> 7 - 9	> 6,4 - 7,9	> 7,5 - 10	> 10 - 11,5	> 8 - 10	> 5,6 - 7		
	(barg)	> 9 - 11,7	> 7,9 - 11,5	> 10 - 12,5	> 11,5 - 16	> 10 - 18	> 7 - 8		
	(barg)	> 11,7 - 16	> 11,5 - 18,5	> 12,5 - 16	> 16 - 18,5		> 8 - 9,3		
	(barg)	> 16 - 22	> 18,5 - 25	> 16 - 22	> 18,5 - 23		> 9,3 - 11,5		
	(barg)	> 22 - 30					> 11,5 - 13		

Capacity saturated steam incl. 10% overpressure

NPS		1"x2"	1 1/2"x2"	1 1/2"x2 1/2"	1 1/2"x3"	2"x3"	3"x4"	4"x6"	6"x8"	6"x10"
Set pressure		Saturated steam kg/h								
0,2	(barg)	126	210	210	324	506	855	2024	2510	3490
0,4	(barg)	185	307	307	473	739	1250	2960	3630	5050
0,5	(barg)	207	344	344	529	827	1400	3310	4070	5660
0,6	(barg)	230	383	383	590	923	1560	3690	4470	6220
0,8	(barg)	272	453	453	698	1090	1840	4360	5240	7280
1	(barg)	317	526	526	811	1270	2140	5070	6030	8385
1,5	(barg)	425	707	707	1090	1700	2875	6800	8050	11200
2	(barg)	477	792	792	1220	1900	3220	7625	10125	14080
2,5	(barg)	572	950	950	1460	2285	3865	9145	11990	16660
3	(barg)	662	1100	1100	1695	2645	4475	10600	13880	19300
4	(barg)	837	1390	1390	2140	3350	5650	13400	17550	24400
5	(barg)	1000	1665	1665	2565	4000	6770	16000	21000	29250
6	(barg)	1165	1940	1940	2990	4665	7890	18650	24500	34050
7	(barg)	1330	2210	2210	3400	5320	9000	21300	27900	38800
8	(barg)	1495	2485	2485	3820	5980	10100	23900	31350	43600
9	(barg)	1660	2755	2755	4245	6630	11200	26500	34800	48400
10	(barg)	1820	3025	3025	4665	7290	12300	29150	38250	53200
11	(barg)	1985	3300	3300	5080	7940	13400	31750	41600	58000
12	(barg)	2150	3570	3570	5500	8590	14500	34350	45100	62700
13	(barg)	2310	3840	3840	5920	9250	15600	37000	48500	67500
14	(barg)	2475	4110	4110	6340	9900	16700	39600	52000	72300
15	(barg)	2640	4385	4385	6760	10550	17800	42200	55400	77000
16	(barg)	2800	4655	4655	7170	11200	18950	44800	58800	81800
17	(barg)	2965	4930	4930	7590	11850	20050	47400	62200	86600
18	(barg)	3130	5200	5200	8010	12500	21150	50100	65700	91400
19	(barg)	3295	5470	5470	8430	13150	22250	52700	69100	96200
20	(barg)	3460	5750	5750	8850	13800	23350	55300	72600	101000
21	(barg)	3620	6020	6020	9250	14500	24500	57900	76000	105800
22	(barg)	3790	6290	6290	9700	15150	25600	60600	79500	110900
24	(barg)	4120	6840	6840	10500	16450	27850	65900	86500	120600
25	(barg)	4280	7120	7120	10950	17100	28950		90200	125500
26	(barg)	4450	7390	7390	11350	17800	30050		93700	130300
27	(barü)	4620	7670	7670	11820	18460	31220		96950	
28	(barg)	4780	7950	7950	12250	19100	32300			
30	(barg)	5120	8500	8500	13100	20450				
32	(barg)	5450	9060	9060	13950	21800				
34	(barg)	5800	9650	9650	14850	23250				
40	(barg)									

Capacity Air incl. 10% Drucksteigerung

NPS		1"x2"	1 1/2"x2"	1 1/2"x2 1/2"	1 1/2"x3"	2"x3"	3"x4"	4"x6"	6"x8"	6"x10"
Set pressure		Air in Nm ³ /h (0°C; 1,013 bara)								
0,2	(barg)	148	246	246	380	594	1003	2375	2945	4100
0,4	(barg)	223	370	370	570	891	1505	3565	4380	6090
0,5	(barg)	252	419	419	646	1009	1705	4035	4970	6910
0,6	(barg)	284	472	472	728	1135	1920	4545	5520	7675
0,8	(barg)	341	567	567	873	1365	2305	5460	6555	9115
1	(barg)	398	661	661	1019	1590	2690	6370	7575	10530
1,5	(barg)	538	894	894	1378	2150	3640	8610	10195	14180
2	(barg)	607	1008	1008	1550	2425	4100	9700	12890	17920
2,5	(barg)	731	1215	1215	1870	2925	4945	11700	15330	21300
3	(barg)	850	1410	1410	2175	3400	5750	13600	17840	24800
4	(barg)	1080	1800	1800	2770	4330	7310	17300	22725	31600
5	(barg)	1300	2160	2160	3330	5210	8800	20840	27350	38000
6	(barg)	1520	2530	2530	3900	6090	10300	24370	31900	44400
7	(barg)	1745	2900	2900	4465	6970	11790	27900	36600	50900
8	(barg)	1965	3260	3260	5030	7860	13280	31430	41200	57300
9	(barg)	2185	3630	3630	5590	8740	14770	34960	45800	63800
10	(barg)	2400	3990	3990	6150	9610	16250	38500	50500	70200
11	(barg)	2625	4360	4360	6720	10500	17750	42000	55100	76600
12	(barg)	2845	4730	4730	7290	11380	19240	45500	59700	83100
13	(barg)	3070	5090	5090	7850	12270	20730	49000	64400	89500
14	(barg)	3290	5460	5460	8400	13150	22200	52600	69000	96000
15	(barg)	3500	5830	5830	8980	14030	23700	56100	73600	102400
16	(barg)	3725	6190	6190	9540	14900	25200	59600	78200	108800
17	(barg)	3950	6560	6560	10100	15800	26700	63100	82900	115300
18	(barg)	4170	6920	6920	10670	16650	28100	66700	87500	121700
19	(barg)	4390	7300	7300	11240	17550	29600	70200	92100	128100
20	(barg)	4610	7660	7660	11800	18400	31150	73700	96800	134600
21	(barg)	4830	8020	8020	12370	19300	32650	77300	101400	141000
22	(barg)	5050	8390	8390	12930	20200	34150	80800	106000	147500
24	(barg)	5490	9120	9120	14060	21970	37100	87900	115300	160400
25	(barg)	5710	9490	9490	14620	22850	38600		120000	166900
26	(barg)	5930	9850	9850	15190	23730	40100		124600	173300
27	(barü)	6160	10240	10240	15770	24630	41650		129350	
28	(barg)	6370	10600	10600	16320	25500	43100			
30	(barg)	6810	11320	11320	17450	27250				
32	(barg)	7250	12050	12050	18570	29000				
34	(barg)	7700	12790	12790	19700	30800				
40	(barg)	9030			23810	36100				

Capacity water incl. 10% overpressure

NPS		1"x2"	1 1/2"x2"	1 1/2"x2 1/2"	1 1/2"x3"	2"x3"	3"x4"	4"x6"	6"x8"	6"x10"
Set pressure		Water m ³ /h								
0,2	(barg)	5,13	8,53	8,53	13,1	20,5	30,8	73	94,9	132
0,5	(barg)	8,12	13,5	13,5	20,8	32,5	48,8	115	150	209
1	(barg)	11,5	19,1	19,1	29,4	45,9	69	163	212	295
2	(barg)	16,2	27	27	41,6	64,9	97,5	231	300	417
3	(barg)	19,9	33	33	50,9	79,5	119	283	368	511
4	(barg)	22,9	38,1	38,1	58,7	91,8	138	326	424	590
5	(barg)	25,7	42,6	42,6	65,5	102	154	365	474	660
6	(barg)	28,1	46,7	46,7	72	112	169	400	520	723
7	(barg)	30,4	50,4	50,4	77,7	121	182	432	562	781
8	(barg)	32,5	53,9	53,9	83,1	130	195	461	600	835
9	(barg)	34,4	57,2	57,2	88,1	138	207	490	637	885
10	(barg)	36,3	60,3	60,3	92,9	145	218	516	671	933
11	(barg)	38	63,2	63,2	97,4	152	229	540	703	977
12	(barg)	39,7	66	66	102	159	239	565	735	1022
13	(barg)	41,4	68,7	68,7	106	165	249	587	764	1062
14	(barg)	42,9	71,3	71,3	110	172	258	611	794	1104
16	(barg)	45,9	76,3	76,3	117	184	276	653	849	1181
18	(barg)	48,7	80,9	80,9	125	195	293	692	900	1252
19	(barg)	49,9	82,9	82,9	128	200	300	710	923	1284
20	(barg)	51,3	85,3	85,3	131	205	308	730	949	1320
21	(barg)	52,6	87,4	87,4	135	210	316	748	973	1350
24	(barg)	56,2	93,4	93,4	144	225	338	800	1040	1443
25	(barg)	57,4	95,3	95,3	147	229	345		1059	1473
26	(barg)	58,5	97,2	97,2	150	234	352		1080	1502
27	(barg)	59,6	99	99	153	238	358		1100	
28	(barg)	60,7	101	101	155	243	365			
30	(barg)	62,9	104	104	161	251				
32	(barg)	64,8	108	108	166	259				
34	(barg)	66,9	111	111	171	268				
40	(barü)	72,5			185,4	289,7				

Approvals	
ARI-SAFE-SN ANSI	ASME Code Section VIII-Division 1 USA
	Canada Registration - CRN only construction with UV-stamp
	Pressure equipment directive PED 97/23/EC Modul H1, B+D
	DIN EN ISO 4126-1 / TRD 421 / AD2000-A2 / VdTÜV 100

Soft sealing disc (optional)						
Pos.	Description	P min.	Material	Temperature range	Marking	
12	Disc	0,5 bar	(lower values on request)	SA276 Gr. 440 / EPDM	-35 °C to +150 °C	E
		0,5 bar		SA276 Gr. 440 / FPM Viton (FKM)	-25 °C to +180 °C	V
		0,5 bar		SA276 Gr. 440 / CR Neoprene	-30 °C to +125 °C	N
		1,0 bar ¹⁾		SA276 Gr. 440 / SHR	-20 °C to +200 °C	S

¹⁾ Fig. 900 DN20 min. 2,0 bar

EPDM-Bellow (optional)			
Pos.	Description	Material	Temperature range
43	EPDM-Bellow	EPDM	-10 °C to +120 °C

Disc: metal seat or soft sealing disc

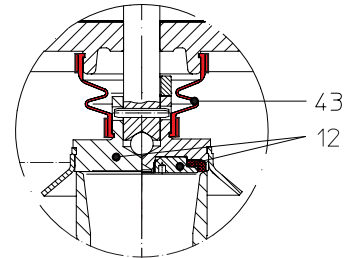

Back pressure compensating stainless steel-bellow with balanced piston (optional)		
Nur für geschlossene Construction!		
Pos.	Description	Material
55	Stainless steel bellow unit	SA 240 Gr. 316 Ti / SA 479 Gr. 316 Ti
70	Balanced piston	SA 240 Gr. 316 Ti

Test: German „TA-Air TÜV-Test-No. 922-960324

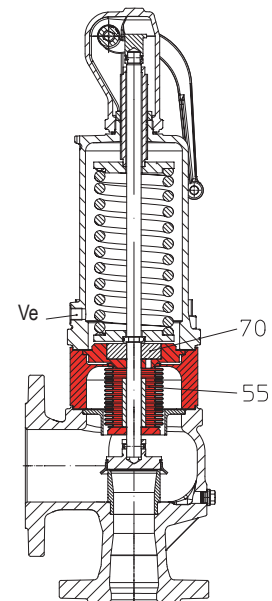

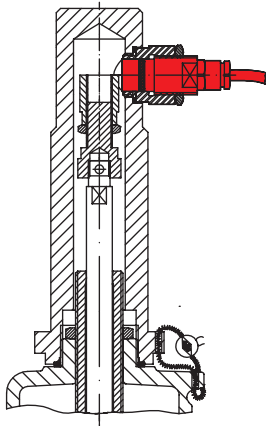

Proximity switch

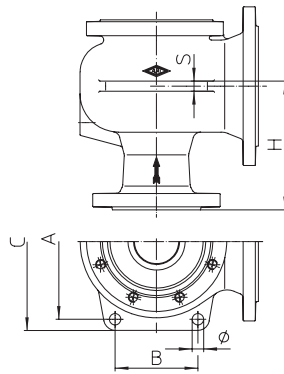

Body material	NPS (inch)	A (mm)	B (mm)	C (mm)	Ø (mm)	S (mm)	H (mm)
SA216WCB	2" x 3"	176	70	204	14	12	155
	3" x 4"	212	90	280			175
	4" x 6"	295	165	332	18	16	230
	6" x 8"	318	183	362	22	20	260
	6" x 10"	360	200	408	22	22	295

Support tongues, drilled

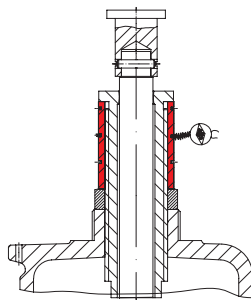

Lock bush

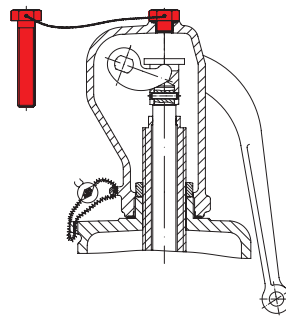

Test gag

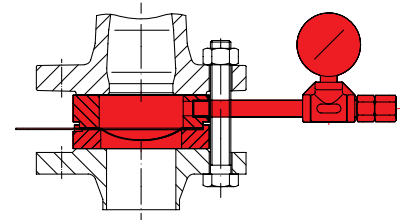

Rupture disc

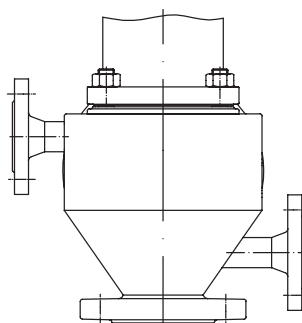

Heating jacket

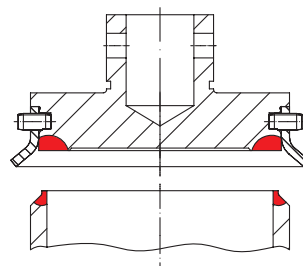
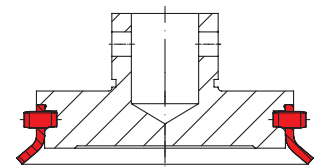
 Seat SA479Gr.316Ti / Stellite No. 21
 Disc SA479Gr.316Ti / Stellite No. 6
 and removable lifting aid

 Removable lifting aid
 Chemical-version SA479Gr.316Ti

MyValve - Calculator
Contents:

Type-test approved acc. to ASME Code Section VIII-Division 1.

Module ARI-Safety valves SAFE-Semi Nozzle-Calculation

- Sizing (Calculation of valve-size with given capacity.)
- Sizing acc. to ASME VIII, API520

Type-test approved acc. to DIN EN ISO 4126-1 / TRD 421 / AD2000-A2

Module ARI-Safety valves SAFE-DIN EN-Calculation

- Sizing (Calculation of valve-size with given capacity.)
- Sizing acc. to DIN EN ISO 4126-1 / TRD 421 / AD2000-A2

Media:

Integrated media-databank (more than 160 media) with conditions:

- Vapours / gases
- Steam (saturated and superheated)
- Liquid

Special features:

- Project administration of the calculation and product data incl. spare part drawings concerning to project and tag number
- Direct output or calculation and product data in PDF format
- Product data could be taken for a direct order
- SI- and ANSI-units with direct conversion to another databank
- Settings with over pressure or absolute pressure
- All ARI Pressure regulating valves are integrated in a databank
- Direct access concerning to the product on data sheets, operating instructions, pressure-temperature-diagram and spare part drawings
- Operation in company networks possible (no complex installations on individually PC's necessary)

System Requirements:

Windows operating systems, Linux, etc.



Technology for the Future.
GERMAN QUALITY VALVES

ARI-Armaturen Albert Richter GmbH & Co. KG, D-33756 Schloß Holte-Stukenbrock,
Tel. +49 52 07 / 994-0, Telefax +49 52 07 / 994-158 or 159 Internet: <http://www.ari-armaturen.com> E-mail: info.vertrieb@ari-armaturen.com