

# Ball Valves

## Type 15215



### Two-piece Flanged Ball Valves, stainless steel, PN16 - 40, DIN EN

full bore, seat rings glass filled PTFE,  
gland packing with PTFE-rings  
with lever and locking device without lock  
face-to-face dimension acc. to DIN EN 558-1 row 27 (F4/5) - short pattern

**Part No. 15215.X.0600**



### Applications:

Suitable for non-toxic gases and fluids, oil, acid, solution and solvent.

Working temperatures: -50°C / -58°F (223K) up to +230°C / +446°F (503K).

Materials	DIN EN	ASTM
1 Body	1.4408	A 351 CF8M
2 Ball	1.4408	A 351 CF8M
3 Seat rings	PTFE-Fiberglass	
4 Stem	1.4401	A 216 Grade 316
5 Packing	PTFE	
6 Lever	1.4308	A 351 CF8

**Essential:** When ordering or requesting an offer please indicate flow medium, working pressure and working temperature.

Standard marking acc. to Pressure Equipment Directive 2014/68/EU (PED).

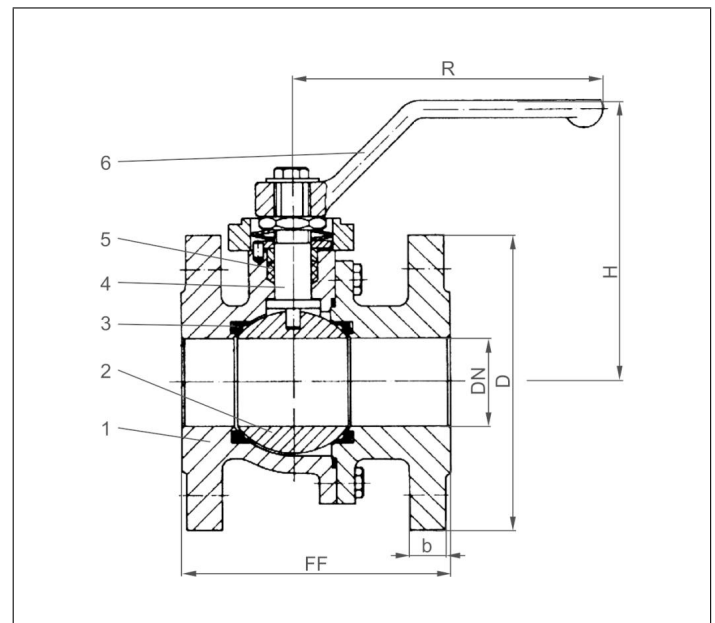

Type 15215	Technical data										
Nominal size	DN	15	20	25	32	40	50	65	80	100	150
Dimension code	X	0150	0200	0250	0320	0400	0500	0650	0800	1000	1500
Max. working pressure	PN	40	40	40	40	40	40	16	40	16	16
Face-to-face dimension	FF	115	120	125	130	140	150	170	180	190	350
Height	H	121	121	121	126	144	153	176	185	202	273
Flange diameter	D	95	105	115	140	150	165	185	200	220	285
Width of flange	b	16	18	18	18	18	20	18	24	20	22
Length	R	155	155	155	155	230	230	230	300	300	800
Weight	approx. kg	3.2	3.7	3.9	5.5	7.3	10.4	16.3	21.4	25.9	95

Dimensions in mm.