

Check Valves

Type 05414 - Check Valve



Cryogenic-Check Valves, PN50 (DN100/150=PN40)

Stainless steel body and cap
with spring, opening pressure ca. 0.1 bar
"cleaned and degreased for oxygen service"

Part No. 05414.X.000*

* Butt weld connection for stainless steel pipes acc. to ISO 1127 or ASTM A312

Part No. 05414.X.0004

Socket weld connection for stainless steel pipes acc. to ISO 1127 or ASTM A312

Available options - on request only:

· Welded stainless steel stubs acc. to ISO 1127 or ASTM A312 - length FF + 200mm



Applications:

Approved for air gases, vapours and cryogenic liquefied gases incl. LNG.

Working temperature: -196°C / -321°F (77K) up to +120°C / +248°F (393K)

Materials	DIN EN	ASTM
1 Body	1.4308	A 351 CF8
2 Valve seal up to DN50	PTFE / Carbon filled (25%)	
2a Valve seal from DN65	PTFE	
3 Disc	1.4301	A 276 Grade 304
4 Spring	1.4571	A 313 Grade 316Ti
5 Bonnet gasket	PTFE	
6 Bolts	1.4301/A2	A 194 B8
7 Cap	1.4301	A 276 Grade 304

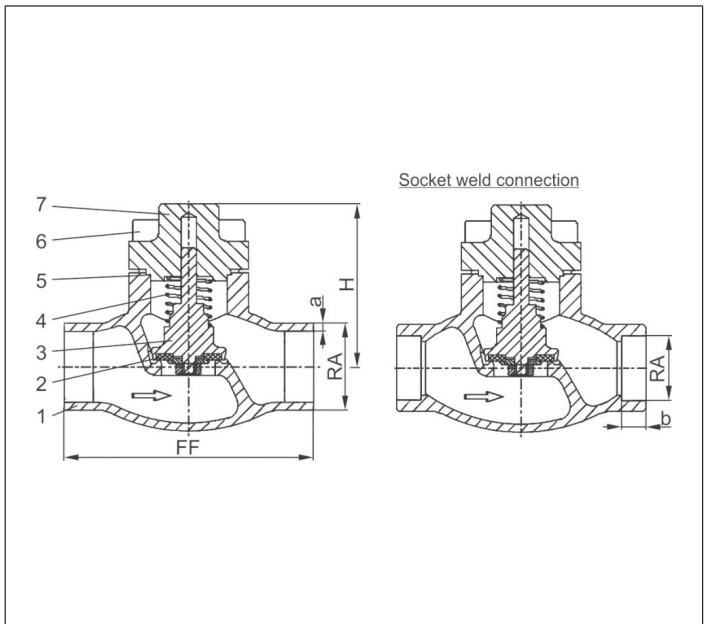

Standard marking acc. to Pressure Equipment Directive 97/23/EC (PED).



Type 05414 - Standard	Technical data														
	DN	10	15	15	20	25	32	40	40	50	65	80	100	150	
Nominal size	.X.	1012	1517	1521	2026	2533	3238	4042	4048	5060	657x	8088	0114	0168	
Dimension code	.X.	1012	1517	1521	2026	2533	3238	4042	4048	5060	657x	8088	0114	0168	
Face-to-face dimension	FF	70	85	85	100	115	115	130	130	155	205	245	280	400	
Height	H	71	71	71	72	75	87	95	95	95	125	150	185	215	
Outside pipe-Ø ISO 1127	RA	12.0	17.2	21.3	26.9	33.7	38.0	42.4	48.3	60.3	76.1	88.9	114.3	168.3	
Wall thickness pipe ISO 1127	a	1.0	1.6	2.0	2.0	2.0	2.0	2.0	2.0	2.0	2.6	3.2	6.0	7.1	
Outside pipe-Ø ASTM A312	RA	13.72	17.15	21.34	26.67	33.40	-	42.16	48.26	60.33	73.03	88.90	114.3	168.3	
Wall thickness pipe ASTM A312	a	dimensions acc. to S10 or S40													
Socket depth	b	6	10	10	13	13	-	13	13	16	16	16	20	20	
Weight	ca. kg	0.7	0.95	1.0	1.3	1.6	2.4	3.9	3.9	5.7	9.6	14.6	20.0	51.0	
Kvs-Value	m ³ /h	1.6	3.8	4.3	6.7	11.5	14.0	20.6	22.6	37.1	71.1	104.0	170.0	350.0	
Cv-Value	gal/min	1.9	4.4	5.0	7.8	13.4	16.2	23.9	26.3	43.2	82.7	120.9	195.2	401.8	

Dimensions in mm. Compliance of tightness requirements acc. to EN 1626 for DN150 up to 20 bar differential pressure. In the range of >20-40 bar, 350-700ml (1 bar, 20°C [68°F]) are reached.

JUSTIN GORAZD s.p.-ATIS
Levstikova ulica 24, 4226 Žiri

Tel.:04 510 5530
Fax:04 510 5531

E-mail: atis@armature.si
WWW: www.armature.si

Offshore Valves

Type 05717 - Check Valve



Cryogenic-Check Valves, PN50

Stainless steel body and cap
with spring, opening pressure ca. 0.1 bar
"cleaned and degreased for oxygen service"

Part No. 05717.X.0001

Female thread connection (G) acc. to ISO 228/1

Part No. 05717.X.0006

Female thread connection NPT acc. to ANSI B 1.20.1

Available options - on request only:

- Female thread connection (R) acc. to ISO 7-Rc



Applications:

Suitable for hydrogen, approved for air gases, vapours and cryogenic liquefied gases incl. LNG.

Working temperature: -255°C / -427°F (18K) up to +120°C / +248°F (393K)

Materials	DIN EN	ASTM
1 Body	1.4409	A 351 CF3M
2 Valve seal up to DN50	PTFE / Carbon filled (25%)	
2 Valve seal from DN65	PTFE	
3 Disc	1.4404	A 276 Grade 316L
4 Spring	1.4571	A 313 Grade 316Ti
5 Bonnet gasket	Graphite	
6 Bolts	1.4571/A4	similar A 194 B8T
7 Cap	1.4404	A 276 Grade 316L

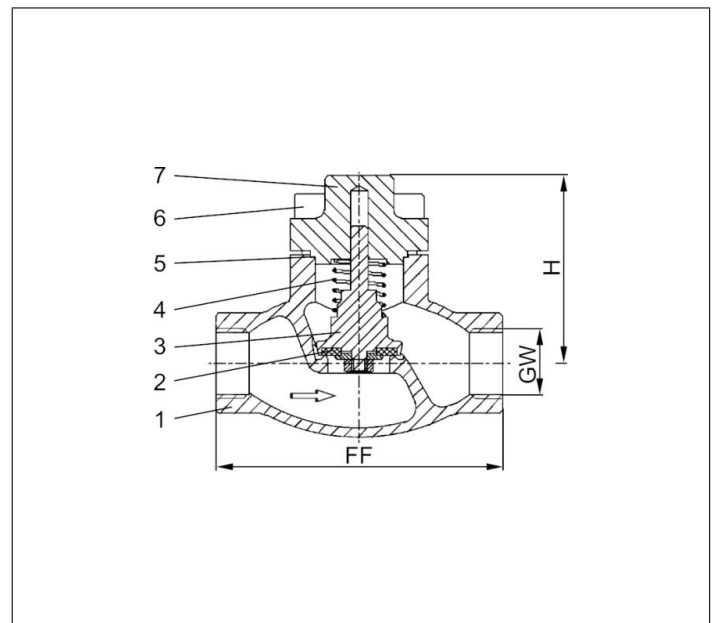

Standard marking acc. to Pressure Equipment Directive 97/23/EC (PED).



Type 05717 - Standard design	Technical data								
Nominal size	DN	10	10	15	20	25	40	40	50
Thread size	GW	1/4	3/8	1/2	3/4	1	1-1/4	1-1/2	2
Dimension code	.X.	0200	0300	0400	0600	1000	1200	1400	2000
Face-to-face dimension	FF	70	70	85	100	115	130	130	155
Height	H	71	71	71	72	75	95	95	95
Weight	ca. kg	0.7	0.7	1.0	1.3	1.6	3.9	3.9	5.7
Kvs-Value	m ³ /h	1.6	2.2	4.3	6.7	11.5	20.6	22.6	37.1
Cv-Value	gal/min	1.9	2.6	5.0	7.8	13.4	23.9	26.3	43.2

Dimensions in mm.

JUSTIN GORAZD s.p.-ATIS
Levstikova ulica 24, 4226 Žiri

Tel.:04 510 5530
Fax:04 510 5531

E-mail: atis@armature.si
WWW: www.armature.si

Check Valves

Type 05417 - Check Valve



Cryogenic-Check Valves, PN50

Stainless steel body and cap
with spring, opening pressure ca. 0.1 bar
"cleaned and degreased for oxygen service"

Part No. 05417.X.0001

Female thread connection (G) acc. to ISO 228/1

Part No. 05417.X.0006

Female thread connection NPT acc. to ANSI B 1.20.1

Available options - on request only:

· Female thread connection (R) acc. to ISO 7-Rc



Applications:

Approved for air gases, vapours and cryogenic liquefied gases incl. LNG.

Working temperature: -196°C / -321°F (77K) up to +120°C / +248°F (393K)

Materials	DIN EN	ASTM
1 Body	1.4308	A 351 CF8
2 Valve seal	PTFE / Carbon filled (25%)	
3 Disc	1.4301	A 276 Grade 304
4 Spring	1.4571	A 313 Grade 316Ti
5 Bonnet gasket	PTFE	
6 Bolts	1.4301/A2	A 194 B8
7 Cap	1.4301	A 276 Grade 304

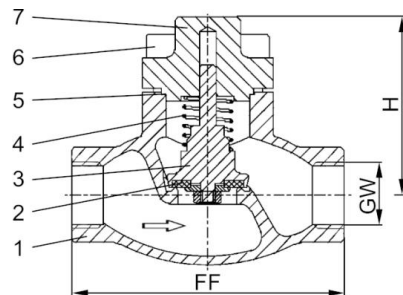

Standard marking acc. to Pressure Equipment Directive 97/23/EC (PED).



Type 05417 - Standard design	Technical data								
Nominal size	DN	10	10	15	20	25	40	40	50
Thread size	GW	1/4	3/8	1/2	3/4	1	1-1/4	1-1/2	2
Dimension code	.X.	0200	0300	0400	0600	1000	1200	1400	2000
Face-to-face dimension	FF	70	70	85	100	115	130	130	155
Height	H	71	71	71	72	75	95	95	95
Weight	ca. kg	0.7	0.7	1.0	1.3	1.6	3.9	3.9	5.7
Kvs-Value	m ³ /h	1.6	2.2	4.3	6.7	11.5	20.6	22.6	37.1
Cv-Value	gal/min	1.9	2.6	5.0	7.8	13.4	23.9	26.3	43.2

Dimensions in mm.

JUSTIN GORAZD s.p.-ATIS
Levstikova ulica 24, 4226 Žiri

Tel.:04 510 5530
Fax:04 510 5531

E-mail: atis@armature.si
WWW: www.armature.si