

Globe Valves

Type 01021



Globe Valves, PN16, DIN 3844

Bronze body, screwed topwork in brass

Part No. 01021.X.0000

Part No. 01021.X.5000 Globe/Check Valve

Female thread connection (G) acc. to ISO 7-1 Rp

Available options - on request only:

- Handwheel in plastic DIN 388-1
- Valve with safety plate in brass



Applications:

Suitable for non-toxic, non-inflammable fluids, gases and vapours.

The laws, regulations and standards are to observe for the range of application.

Working temperatures and pressures:

up to max. 16.0 bar: -10°C / +14°F (263K) up to +80°C / +176°F (353K)

up to max. 10.0 bar: -10°C / +14°F (263K) up to +120°C / +248°F (393K)

up to max. 6.0 bar: -10°C / +14°F (263K) up to +160°C / +320°F (433K)

Materials	DIN EN	ASTM
1 Body	CC491K	B 62 UNS C83600
2 Valve seal	PTFE	
3 Disc	CW614N	B 283 UNS C38500
4 Headpiece	CW614N	B 283 UNS C38500
5 Stem	CW614N	B 283 UNS C38500
6 Handwheel	Aluminium - diecasting	
7 Spring	1.4310	A 313 Grade 301

Essential: When ordering or requesting an offer please indicate flow medium, working pressure and working temperature.

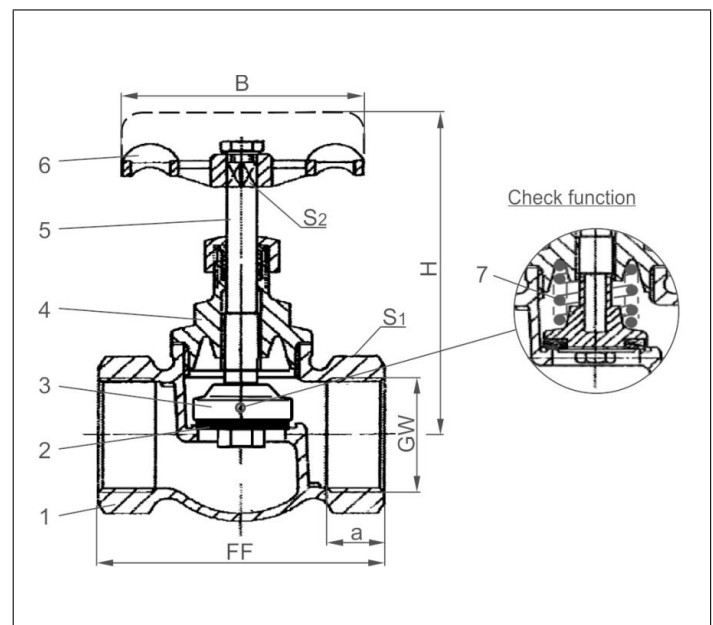

Standard marking acc. to Pressure Equipment Directive 2014/68/EU (PED).



Type 01021	Technical data									
Nominal size	GW	1/4	3/8	1/2	3/4	1	1-1/4	1-1/2	2	
Dimension code	.X.	0200	0300	0400	0600	1000	1200	1400	2000	
Face-to-face dimension	FF	50	50	60	70	80	95	105	130	
Height	H	75	75	85	95	105	120	130	145	
Socket depth	a	9	10	13	14	17	19	19	23	
Handwheel-Ø	B	40	40	50	60	70	80	90	110	
Wrench size across flats	S ₁	22	22	27	32	41	50	58	70	
Wrench size across flats	S ₂	4.5	4.5	5	6	7	8	9	9	
Weight	ca. kg	0.25	0.25	0.3	0.43	0.7	1.0	1.3	2.1	

Dimensions in mm.