

# Ball Valves

## Type 15080, Type 15081 - Ball Valve full bore



### Cryogenic-3-Piece-Ball Valve

Stainless steel body and topwork,  
 "live loaded" gland packing  
 "cleaned and degreased for oxygen service"  
 with upstream pressure relief hole  
 Marking acc. to EN 1626 and EN 12567

#### Part No. 15080.X.0020

Socket weld connection for stainless steel pipes acc. to ISO 1127

#### Part No. 15081.X.0020

Butt weld connection for stainless steel pipes acc. to ISO 1127

Available options - on request only:

- End connection for pipes acc. to ASTM A312 S10/S40
- Stainless steel lockable handle
- With pneumatic actuator
- ATEX Ex II 2GD



### Applications:

Approved for air gases, vapours and cryogenic liquefied gases.

Working temperature: -200°C / -328°F (73K) up to +200°C / +392°F (473K)

Materials	DIN EN	ASTM
1 Body	1.4409	A 351 CF3M
2 Ball seat	PTFE / Carbon filled (25%)	
3 Ball	1.4409	A 351 CF3M
4 Fitting	1.4404	A 276 Grade 316L
5 Flange	1.4306	A 276 Grade 304L
6 Stem	1.4404	A 276 Grade 316L
7 Elongation tube	1.4306	A 312 TP 304L
8 Gland packing up to DN50	33% C + 2% Gr PTFE	
8a Gland packing from DN65	PTFE	
9 Lever	1.1181	1035

Standard marking acc. to Pressure Equipment Directive 97/23/EC (PED).

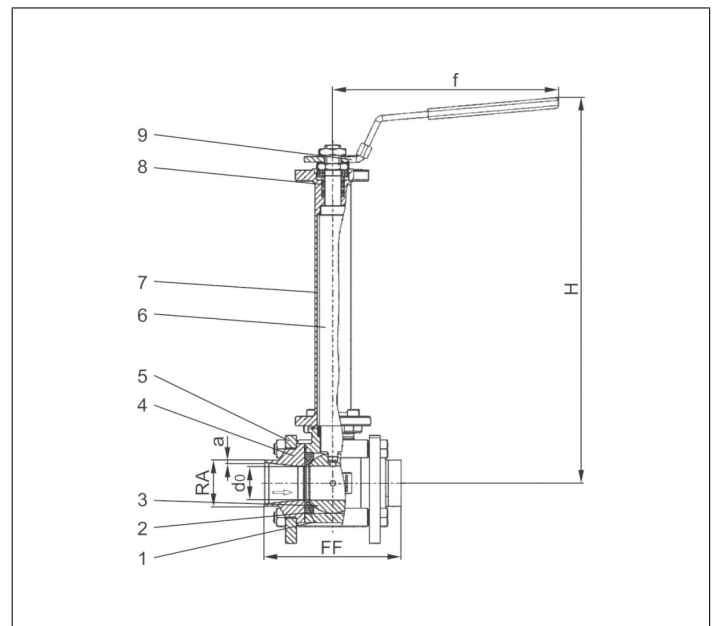

Type 15080, 15081	Technical data											
	DN	8	12	15	20	25	32	40	50	65	80	100
Nominal size	DN	8	12	15	20	25	32	40	50	65	80	100
Dimension code	.X.	0813	1217	1521	2026	2533	3242	4048	5060	6576	8088	0114
Nominal pressure	PN	100	100	100	100	70	70	50	50	40	40	25
Face-to-face dimension	FF	65	65	70	85	100	110	125	150	180	210	230
Height	H	225	225	230	276	280	321	326	346	426	438	471
Outside pipe-Ø ISO 1127	RA	13.5	17.2	21.3	26.9	33.7	42.4	48.3	60.3	76.1	88.9	114.3
Wall thickness pipe ISO 1127	a	2.0	2.0	2.0	2.0	2.0	2.6	2.6	2.9	2.9	2.9	3.2
Orifice	d <sub>0</sub>	11.1	11.1	14.0	19.0	25.0	32.0	38.0	50.0	64.0	76.0	100.0
Length	f	118	118	118	158	158	188	188	225	370	440	505
Weight	ca. kg	1.05	1.05	1.45	2.35	3.05	4.55	6.30	11.10	20.15	32.22	45.00
Kvs-Value	m <sup>3</sup> /h	6.0	8.0	13.0	26.0	46.0	82.0	120.0	223.0	423.0	617.0	1154.0
Cv-Value	gal/min	6.9	9.2	15.0	30.0	53.2	94.8	138.7	257.8	489.0	713.3	1334.0

Dimensions in mm.

JUSTIN GORAZD s.p.-ATIS  
 Levstikova ulica 24, 4226 Žiri

Tel.:04 510 5530  
 Fax:04 510 5531

E-mail: atis@armature.si  
 WWW: www.armature.si