

LARSLAP MODEL FL

## Individually driven grinding heads: means perfect results in a short amount of time.

A midrange portable machine for gate, parallel slide, globe, check, safety and control valves, discs and wedges.

- Suitable for valves with flat Seats  $\varnothing$  50–300 mm (2"–12")
- Individually driven grinding heads for perfectly flat seats
- Gives you an absolutely flat sealing surface.
- Air drive unit as standard 6–7 bar
- Electric drive unit available
- Variable grinding speed on all drive units
- Supplied with a mounting plate for grinding discs and wedges
- Self-adhesive grinding discs for quick attachment to the grinding heads
- Supplied with rough, medium and fine grinding discs
- Heavy duty carrying/storage case for the complete machine with all the necessary accessories
- Extended grinding heads available
- Very thin section driving heads available
- Grinding heads for angled seats available
- Self-adhesive grinding discs 40 to 1000 grit available
- Diamond grinding discs available.

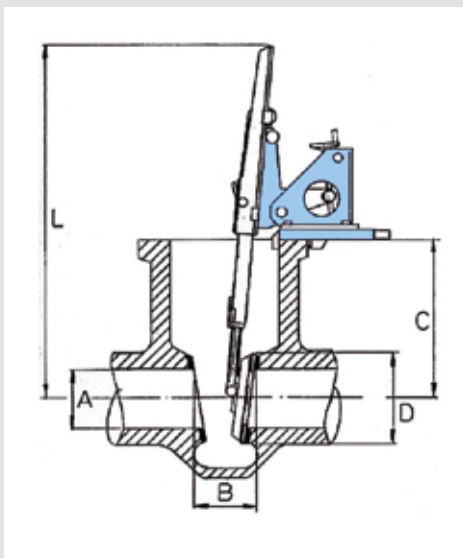

### Model FL

A:	50–300 mm (2"–12")
B:	39 mm (1,56") min
C:	100 mm (4") min 600 mm (24") standard 1000 mm (60") max (option)
D:	80–357 mm (3,20"–14,8")
L:	570 mm (22,8") min
Carrying case:	280 x 560 x 760 mm 11.2" x 22,4" x 30,4"
Total weight:	39 kg (87,8 lb)

Tools with the cutting edge

# LarsLap Model FL

Suitable for gate, globe, check,  
safety, control valves and gate  
valve wedges  
**Range: 50-300mm (2"-12")**



# Tools with the cutting edge

## LarsLap – the optimal grinding system



**Repairing leaking valves** in industrial pipelines is a laborious operation involving extended downtime, production losses and substantial, unwanted costs.

**Losses are minimized** if valves can be reground *in situ*, precluding the need to dismantle and remove defective valves from the pipeline.

**LarsLap'portable**, industrial valve grinders with their patented design concept are the proven solution for on-line valve reconditioning.

**Available in overlapping sizes**, LarsLap grinders combine unsurpassed versatility with exceptional ease of handling and operation.

**A combination guaranteed** to give LarsLap grinders cutting edge performance, whatever the valve location.

Welcome to the world of LarsLap

### LarsLap model FL

The best way to a perfect result

#### On-line grinding for fast results

LarsLap model FL's unique, lightweight universal clamping system allows rapid, accurate mounting for grinding valve seats or wedges.

Operating checks and replacement of abrasive discs can be carried out without disturbing the assembly. No realignment is necessary when repositioning the grinding head.



# Tools with the cutting edge



## Individually driven grinding heads for perfect results

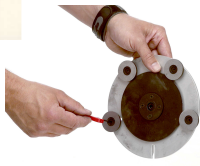

Drive heads on LarsLap model FL incorporate individually gear driven grinding discs, permitting rapid and efficient grinding of exceptionally smooth, flat surfaces for tightest possible seats.

## Versatile

The Model FL can be mounted easily to grind the flanges on the valves, we also supply a 3 degree kit for gate valves, this reduces the risk of cutting damages to the seat.

To cover your needs the FL can be equipped with a range of driving and grinding heads permitting numerous combinations within the 40-300 mm range (1,6"-12").



## Horizontal or vertical grinding

With the model FL you have the option to grind globe valves (model FL-B), gate valves and wedges (FL-C) or both (FL-BC).



## Wedges

The model FL valve grinder is easily set up for wedge grinding using the existing clamping system.



## Complete with carrying case

Every LarsLap model FL is supplied with a rugged, customized carrying/storage case complete with accessories.

The case is fitted with specially designed compartments molded to the shape of each component, allowing operators to confirm at glance that all items are in place before and after grinding.

## Unique flexibility

All LarsLap grinders are designed for operational compatibility. They can be run from bench-mountings and driven by pneumatic or electric powered motors. Equipment purchased initially for relatively small diameter ranges can be conveniently upgraded to deal with larger ranges at a later date.

This unique degree of flexibility means that grinders can be readily adapted to suit a wide variety of customer needs.



## LarsLap Grinding paper

Get the most out of your machine by using LarsLap original grinding paper. LarsLap grinding paper is tested, proved and perfectly fitted to suit your machine under the conditions it will be working in. (from 24 grit to 3mic)

## Larslap model FL

A selection of standard models  
Other configurations and  
accessories are available on  
request

### FL B 200

50-200mm  
(2"-8")  
Globe, control  
and safety  
valves

### FL B 300

50-300mm  
(2"-12")  
Globe, control  
and safety  
valves

### FL C 200

50-200mm  
(2"-8")  
Gate, check  
valves and  
wedges

### FL C 300

50-300mm  
(2"-12")  
Gate, check  
valves and  
wedges

### FL BC 200

50-200mm  
(2"-8")  
Gate, check,  
globe, control,  
safety valves  
and wedges

### FL BC 300

50-300mm  
(2"-12")  
Gate, check,  
globe, control,  
safety valves  
and wedges

Base unit	•	•	•	•	•	•
Bottom plate for grinding gate valve wedges	option	option	•	•	•	•
Drive shaft for gate valves	option	option	•	•	•	•
Drive shaft for globe valves	•	•	option	option	•	•
Electric drive unit 110 or 220V	option	option	option	option	option	option
Pneumatic drive unit (6-7 bar)	option	option	option	option	option	option
Regulator for pneumatic drive unit	option	option	option	option	option	option
Holder for drive shaft. Maximum depth 600mm (24")	•	•	•	•	•	•
Holder for drive shaft. Maximum depth 900mm(36")	option	•	option	•	option	•
Driving plate FL Ø 50mm (2")	•	•	•	•	•	•
Driving head FL Ø 65mm (2,5")	•	•	•	•	•	•
Driving head FL Ø 80mm (3")	•	•	•	•	•	•
Driving head FL Ø 100mm (4")	•	•	•	•	•	•
Driving head FL Ø 125mm (5")	•	•	•	•	•	•
Driving head FL Ø 150mm (6")	•	•	•	•	•	•
Driving head FL Ø175mm (7")	option	option	option	option	option	option
Driving head FL Ø 200mm (8")	•	•	•	•	•	•
Driving head FL Ø 225mm (9")	option	option	option	option	option	option
Driving head FL Ø 250mm (10")	option	•	option	•	option	•
Driving head FL Ø 300mm (12")	option	•	option	•	option	•
FL grinding head ø28mm (1,1")	•	•	•	•	•	•
FL grinding head ø35mm (1,4")	•	•	•	•	•	•
FL grinding head ø 40mm (1,6")	•	•	•	•	•	•
FL grinding head ø 50mm (2")	option	option	option	•	option	•
FL grinding head ø 70mm (2,8")	option	option	option	option	option	option
Conical segments in different angles Ø65 – 200mm (2 ½" – 8")	option	option	option *	option *	option	option
Transport and storage case with tools required to operate the FL	•	•	•	•	•	•
Grinding discs rough, medium and fine ø 28/35/40mm	•	•	•	•	•	•

\*Requires B drive shaft

### Possible range for model FL

- A= 40-300 mm (1,6"-12")  
 B= 39 mm (1,56") min  
 C= 100mm (4") min  
 600mm (24") standard  
 1000 mm (60") max (option)  
 D= 80- 507 mm (3,20"-14,8")  
 L= 570 mm (22,8") min

Carrying case Model FL-BC 200:  
760x560x280mm (30,4"x22,4"x11,2")  
Total weight Model FL-BC 200:  
39 kg (87,8 lb)

